



FM - FMC - FGM - FF

**CE 0051
 0497**



DESCRIZIONE

E' un dispositivo che impedisce il passaggio di particelle di polvere o detriti portati dal gas proteggendo i dispositivi di regolazione e sicurezza.

E' composto da una cartuccia filtrante ampiamente dimensionata e realizzata in materiale sintetico lavabile; è completamente estraibile per una totale ispezione e pulizia.

Ciò è notevolmente facilitato dalle tenute appositamente realizzate con anelli di tipo O-Ring resistenti anche ai gas della terza famiglia.

Ogni filtro MADAS consente la misurazione della pressione a monte tramite un apposito attacco a norma.

Omologazione CE secondo EN 126

Conforme Direttiva 2009/142/CE (Direttiva Gas)

Conforme Direttiva 97/23/CE (Direttiva PED)

DESCRIPTION

It is a device that prevents the passage of a particles of dust or debris brought by the gas, protecting the regulation and safety device.

FM gas filters have a large filtering component made of synthetical washable material which is fully removable for complete inspection and cleaning.

Special O-Ring sealings, resistant to third gas family, make easy removal.

MADAS filters permits upstream pressure measurement through an appropriate standard connection.

EC certified according to EN 126

In conformity with the 2009/142/EC Directive (Gas Directive)

In conformity with the 97/23/EC Directive (PED Directive)

DESCRIPTION

Les filtres pour gaz éliminent les particules de poussière portées par le gaz et protègent les éléments en danger (brûleurs, compteurs et régulateurs) d'une obstruction rapide.

Filtre pour gaz est composé d'une cartouche filtrante réalisée en matériau synthétique lavable; il est complètement extractible pour l'inspection complète et le nettoyage.

Cela est facilité par les joints d'étanchéité tout spécialement réalisés avec des bagues de type joints toriques qui résistent aussi aux gaz de la troisième famille.

Chaque filtre MADAS permet le mesurage de la pression en haut grâce à une fixation spéciale.

Homologation CE selon EN 126

Conforme à la Directive 2009/142/CE (Directive Gaz)

Conforme à la Directive 97/23/CE (Directive PED)

DESCRIPCIÓN

Dispositivo que impide el paso de partículas de polvo o impurezas contenidas en el gas, protegiendo así los dispositivos de regulación y seguridad.

Es compuesto por un cartucho filtrante de material sintético lavable y es completamente extraíble para una inspección y limpieza completas.

Estas operaciones son sumamente facilitadas por la presencia de juntas tóricas, resistentes también a los gases de la tercera familia.

Es posible efectuar la medición de la presión en los puntos anteriores de la línea, a través de una conexión expresamente provista según la norma.

Homologación CE según EN 126

Conforme Directiva 2009/142/CE (Directiva Gas)

Conforme Directiva 97/23/CE (Directiva PED)



CARATTERISTICHE TECNICHE

- Impiego:
gas non aggressivi delle 3 famiglie
(gas secchi)
- Attacchi filettati Rp:
(DN 15 ÷ DN 50) secondo EN 10226
- Attacchi flangiati PN 16:
(DN 65 ÷ DN 300) secondo ISO 7005
- Su richiesta attacchi flangiati ANSI 150
- Pressione max esercizio:
2 bar o 6 bar (vedere etichetta prodotto)
- Temperatura ambiente:
-20 ÷ +70 °C
- Gruppo:
2
- Filtraggio:
50 µm - 20 µm - 10 µm

MATERIALI

- Alluminio pressofuso (UNI EN 1706)
- ottone OT-58 (UNI EN 12164)
- alluminio 11S (UNI 9002-5)
- acciaio zincato e acciaio INOX 430 F
(UNI EN 10088)
- gomma antiolio NBR (UNI 7702)
- nylon 30% fibra di vetro
(UNI EN ISO 11667)
- viledon

MODELLI

A = Senza prese di pressione o tappi
B = 1 Presa di pressione G 1/8" in entrata
D = Presa di pressione G 1/8" in entrata e uscita
F = 1 Tappo G 1/8" in entrata
H = Tappo G 1/8" in entrata e uscita
I = 4 Tappi G 1/4"
L = 2 Prese di Pressione + 2 Tappi G 1/8"
M = Presa di pressione G 1/4" in entrata e uscita
N = 4 Prese di pressione G 1/4"
O = 2 Prese di Pressione + 2 Tappi G 1/4"
J = Tappo G 1/4" in entrata e uscita



TECHNICAL DATA

- Use:
not aggressive gases of the 3 families
(dry gases)
- Threaded connections Rp:
(DN 15 ÷ DN 50) according to EN 10226
- Flanged connections PN 16:
(DN 65 ÷ DN 300) according to ISO 7005
- On request ANSI 150 flanged connections
- Max. working pressure:
2 bar or 6 bar (see product label)
- Environment temperature:
-20 ÷ +70 °C
- Group:
2
- Filtration:
50 µm - 20 µm - 10 µm

MATERIALS

- Die-cast aluminium (UNI EN 1706)
- OT-58 brass (UNI EN 12164)
- 11S aluminium (UNI 9002-5)
- galvanized and 430 F stainless steel
(UNI EN 10088)
- NBR rubber (UNI 7702)
- nylon 30% glass fibre
(UNI EN ISO 11667)
- viledon

MODELS

A = Without pressure nipples or caps
B = Inlet G 1/8" pressure nipple
D = Inlet and outlet G 1/8" pressure nipple
F = Inlet G 1/8" cap
H = Inlet and outlet G 1/8" cap
I = 4 G 1/4" caps
L = 2 G 1/8" pressure nipples and 2 G 1/8" caps
M = Inlet and outlet G 1/4" pressure nipple
N = 4 G 1/4" pressure nipples
O = 2 G 1/4" pressure nipples and 2 G 1/4" caps
J = Inlet and outlet G 1/4" cap



CARACTERISTIQUES TECHNIQUES

- Emploi:
gaz non agressifs des trois familles
(gaz secs)
- Fixations filetees Rp:
(DN 15 ÷ DN 50) selon EN 10226
- Fixations bridees PN 16:
(DN 65 ÷ DN 300) selon ISO 7005
- Sur demande fixations bridees ANSI 150
- Pression maximale en exercice:
2 bar ou 6 bar (Voir étiquette du produit)
- Température ambiante:
-20 ÷ +70 °C
- Groupe:
2
- Filtrage:
50 µm - 20 µm - 10 µm

MATÉRIELS

- Alluminium fondé dans la masse
(UNI EN 1706)
- laiton OT-58 (UNI EN 12164)
- alluminium 11S (UNI 9002-5)
- acier zingué et acier INOX 430 F
(UNI EN 10088)
- caoutchou anti-huile NBR (UNI 7702)
- nylon 30% fibre de verre
(UNI EN ISO 11667)
- viledon

MODELES

A = Sans prises de pression ou bouchons
B = Prise de pression G 1/8" en 'entrée
D = Prise de pression G 1/8" en entrée/sortie
F = 1 Bouchon G 1/8" en entrée
H = Bouchon G 1/8" en entrée/sortie
I = 4 Bouchons G 1/4"
L = 2 Prises de Pression + 2 Bouchons G 1/8"
M = Prise de pression G 1/4" en entrée/sortie
N = 4 Prises de pression G 1/4"
O = 2 Prises de pression + 2 Bouchons G 1/4"
J = Bouchon G 1/4" en entrée/sortie



CARACTERISTICAS TECNICAS

- Utilizaciòn:
gases de las 3 familias
(secos y no agresivos)
- Conexiones roscadas Rp:
(DN 15 ÷ DN 50) según EN 10226
- Conexiones de brida PN 16:
(DN 65 ÷ DN 300) según ISO 7005
- A petición conexiones de brida ANSI 150
- Max. presion ejercicio:
2 bar o 6 bar (ver etiqueta producto)
- Temperatura ambiente:
-20 ÷ +70 °C
- Grupo:
2
- Filtraciòn:
50 µm - 20 µm - 10 µm

MATERIALES

- Aluminio inyectado a presión
(UNI EN 1706)
- latòn OT-58 (UNI EN 12164)
- aluminio 11S (UNI 9002-5)
- acero inox 430 F y galvanizado
(UNI EN 10088)
- goma antiaceite NBR (UNI 7702)
- nylon 30% fibra de vidrio
(UNI EN ISO 11667)
- viledon

VERSIONES

A = Sin tomas de presión o tapones
B = 1 Toma de presión G 1/8" en entrada
D = Toma de presión G 1/8" en entrada/salida
F = 1 Tapón G 1/8" en entrada
H = Tapón G 1/8" en entrada/salida
I = 4 Tapones G 1/4"
L = 2 Tomas de presión + 2 Tapones G 1/8"
M = Toma de presión G 1/4" en entrada/salida
N = 4 Tomas de presión G 1/4"
O = 2 Tomas de presión + 2 Tapones G 1/4"
J = Tapón G 1/8" en entrada/salida

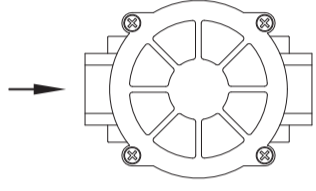
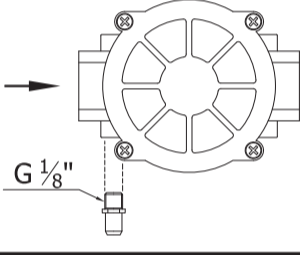
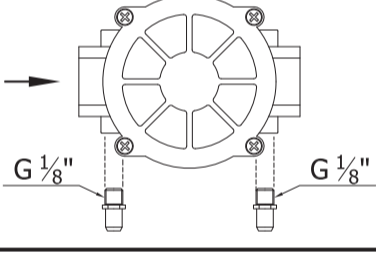
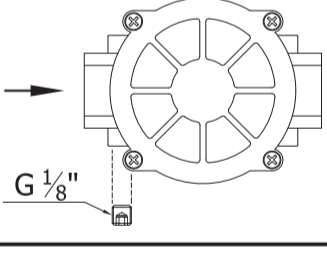
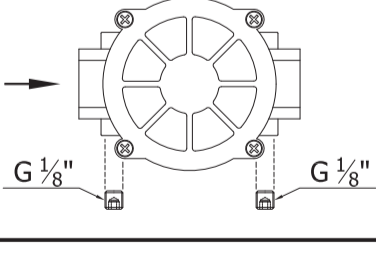
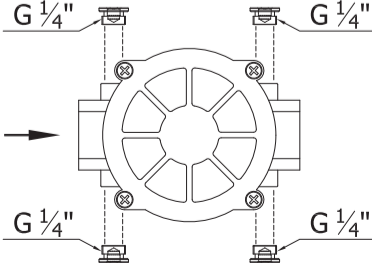
Modello Model Modèle Versión	Attacchi - Connections - Fixations - Conexiones							
	FMC COMPACT DN 15 - DN 20 - DN 25	FM DN 15 - DN 20 - DN 25	FM DN 25M * - DN 32 DN 40 - DN 50	FGM DN 25M * - DN 32 DN 40 - DN 50	FF DN 32 - DN 40 - DN 50	FM DN 65 - DN 20 - DN 25	FM DN 65 - DN 80 - DN 100 DN 125 - DN 150	FM DN 200 - DN 300
A 	✓	✓	✓	✓	✓	✓	✓	✗
B 	✓	✓	✓	✓	✓	✓	✓	✗
D 	✓	✓	✓	✓	✓	✓	✓	✗
F 	✓	✓	✓	✓	✓	✓	✓	✗
H 	✓	✓	✓	✓	✓	✓	✓	✗
I 	✗	✗	✓	✗	✓	✓	✓	✗

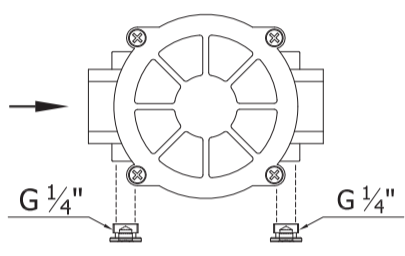
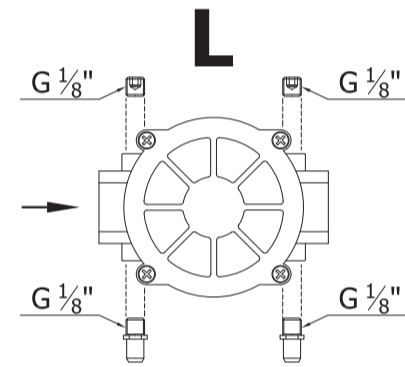
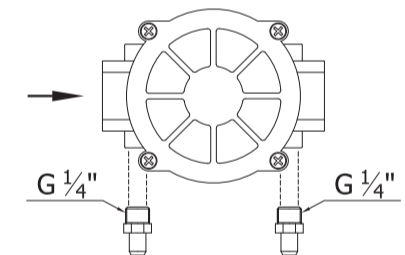
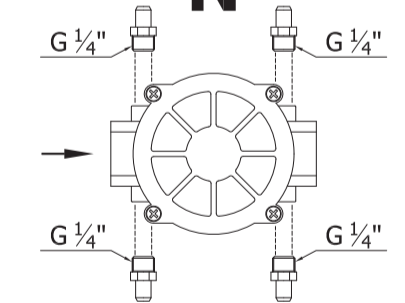
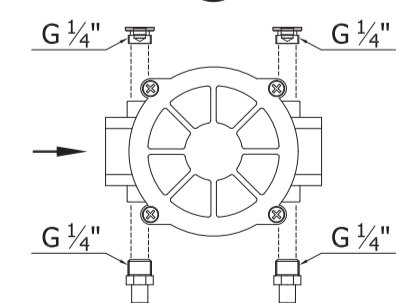
Attacchi - Connections - Fixations - Conexiones								
Modello Model Modèle Versión	FMC COMPACT DN 15 - DN 20 - DN 25	FM DN 15 - DN 20 - DN 25	FM DN 25M * - DN 32 DN 40 - DN 50	FGM DN 25M * - DN 32 DN 40 - DN 50	FF DN 32 - DN 40 - DN 50	FM DN 65 - DN 20 - DN 25	FM DN 65 - DN 80 - DN 100 DN 125 - DN 150	FM DN 200 - DN 300
<p>J</p> 	✓	✗	✓	✓	✓	✓	✓	✓
<p>L</p> 	✗	✓	✓	✗	✓	✓	✓	✗
<p>M</p> 	✓	✗	✓	✓	✓	✓	✓	✓
<p>N</p> 	✗	✗	✓	✗	✓	✓	✓	✗
<p>O</p> 	✗	✗	✓	✗	✓	✓	✓	✗

P. max 2 bar		Attacchi Filettati - Threaded Connections Fixations filetees - Conexiones roscadas					
Foto Photo	Attacchi Connections Fixations Conexiones	Filtraggio 50 micron Filtering 50 micron		Filtraggio 20 micron Filtering 20 micron		Filtraggio 10 micron Filtering 10 micron	
		Codice Code		Codice Code		Codice Code	
	DN 15	FMC02	B50	FMC02	B20	FMC02	B10
	DN 20	FMC03	B50	FMC03	B20	FMC03	B10
	DN 25	FMC04	B50	FMC04	B20	FMC04	B10
	DN 15	FM02	B50	FM02	B20	FM02	B10
	DN 20	FM03	B50	FM03	B20	FM03	B10
	DN 25	FM04	B50	FM04	B20	FM04	B10
	FM DN 25M *	FM04M	B50	FM04M	B20	FM04M	B10
	FM DN 32	FM05	B50	FM05	B20	FM05	B10
	FM DN 40	FM06	B50	FM06	B20	FM06	B10
	FM DN 50	FM07	B50	FM07	B20	FM07	B10
	FGM DN 25M *	FGM04M	B50	-	-	-	-
	FGM DN 32	FGM05	B50	-	-	-	-
	FGM DN 40	FGM06	B50	-	-	-	-
	FGM DN 50	FGM07	B50	-	-	-	-
P. max 2 bar		Attacchi Flangiati - Flanged Connections Fixations Bridees - Conexiones de Brida					
	FM DN 25	FM25	B50	FM25	B20	FM25	B10
	FM DN 25M *	FM25M	B50	FM25M *	B20	FM25M *	B10
	FGM DN 25M *	FGM25M	B50	-	-	-	-
	FF DN 32	FF32	B50	-	-	-	-
	FF DN 40	FF40	B50	-	-	-	-
	FF DN 50	FF50	B50	-	-	-	-
	FM DN 65	FF08	B50	FF08	B20	FF08	B10
	FM DN 80	FF09	B50	FF09	B20	FF09	B10
	FM DN 100	FF10	B50	FF10	B20	FF10	B10
	FM DN 125	-	-	-	-	FF11	B10
	FM DN 150	-	-	-	-	FF12	B10
	FM DN 200	-	-	-	-	FF13	M10
	FM DN 300	-	-	-	-	FF15	M10

P. max 6 bar		Attacchi Filettati - Threaded Connections Fixations filetees - Conexiones roscadas			
Foto Photo	Attacchi Connections	Filtraggio 50 micron Filtering 50 micron	Filtraggio 20 micron Filtering 20 micron	Filtraggio 10 micron Filtering 10 micron	
		Codice Code	Codice Code	Codice Code	
	DN 15	FMC020000 B50	FMC020000 B20	FMC020000 B10	
	DN 20	FMC030000 B50	FMC030000 B20	FMC030000 B10	
	DN 25	FMC040000 B50	FMC040000 B20	FMC040000 B10	
	DN 15	FM020000 B50	FM020000 B20	FM020000 B10	
	DN 20	FM030000 B50	FM030000 B20	FM030000 B10	
	DN 25	FM040000 B50	FM040000 B20	FM040000 B10	
	FM DN 25M *	FM04M0000 B50	FM04M0000 B20	FM04M0000 B10	
	FM DN 32	FM050000 B50	FM050000 B20	FM050000 B10	
	FM DN 40	FM060000 B50	FM060000 B20	FM060000 B10	
	FM DN 50	FM070000 B50	FM070000 B20	FM070000 B10	
	FGM DN 25M *	FGM04M0000 B50	-	-	
	FGM DN 32	FGM050000 B50	-	-	
	FGM DN 40	FGM060000 B50	-	-	
	FGM DN 50	FGM070000 B50	-	-	
P. max 6 bar		Attacchi Flangiati - Flanged Connections Fixations Bridees - Conexiones de Brida			
	FM DN 25	FM250000 B50	FM25 B20	FM25 B10	
	FM DN 25M *	FM25M0000 B50	FM25M * B20	FM25M * B10	
	FGM DN 25M *	FGM25M0000 B50	-	-	
	FF DN 32	FF320000 B50	-	-	
	FF DN 40	FF400000 B50	-	-	
	FF DN 50	FF500000 B50	-	-	
	FM DN 65	FF080000 B50	FF08 B20	FF08 B10	
	FM DN 80	FF090000 B50	FF09 B20	FF09 B10	
	FM DN 100	FF100000 B50	FF10 B20	FF10 B10	
	FM DN 125	-	-	FF11 B10	
	FM DN 150	-	-	FF12 B10	
	FM DN 200	-	-	FF13 M10	
	FM DN 300	-	-	FF15 M10	

fig. 1

FMC DN 15 ÷ 25

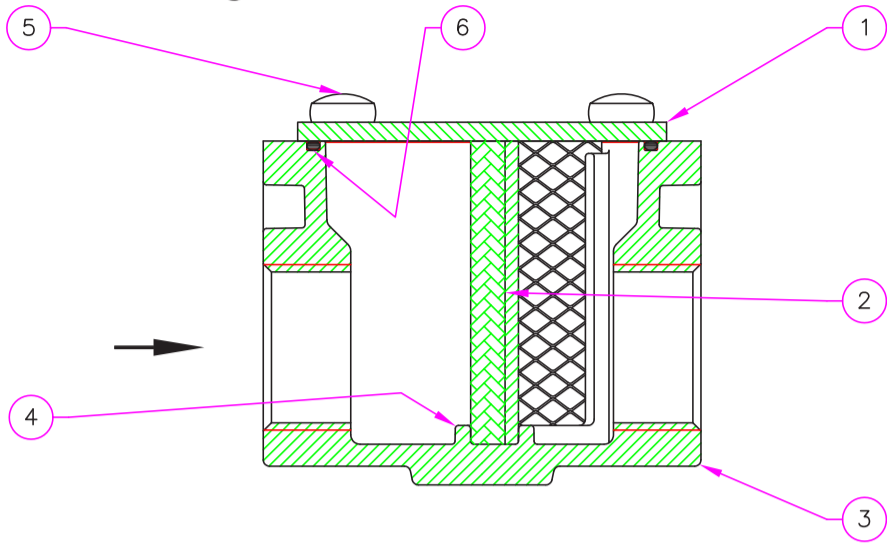

vista dall'alto senza coperchio
view from above without cover
vue du haut sans couvercle
vista superior sin tapa

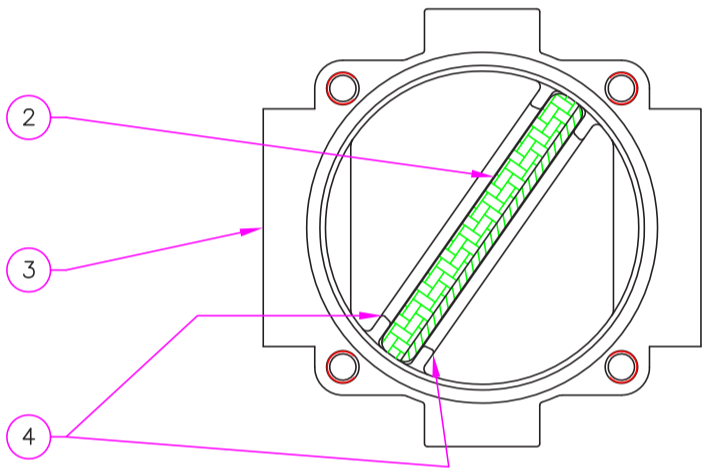

FM DN 15 ÷ 25

fig. 2

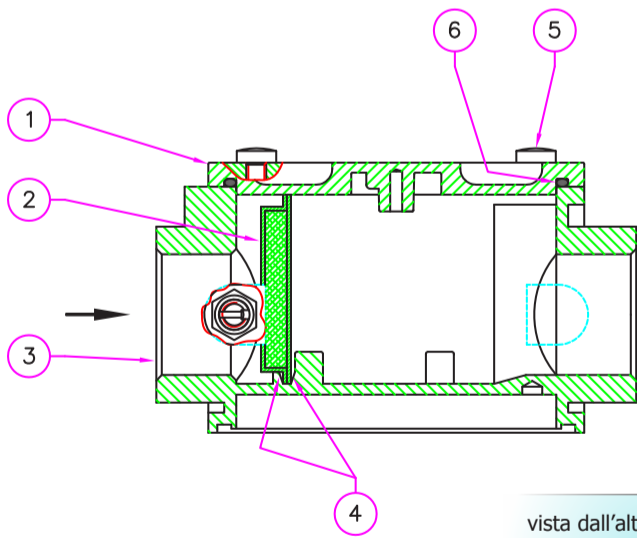

vista dall'alto senza coperchio
view from above without cover
vue du haut sans couvercle
vista superior sin tapa

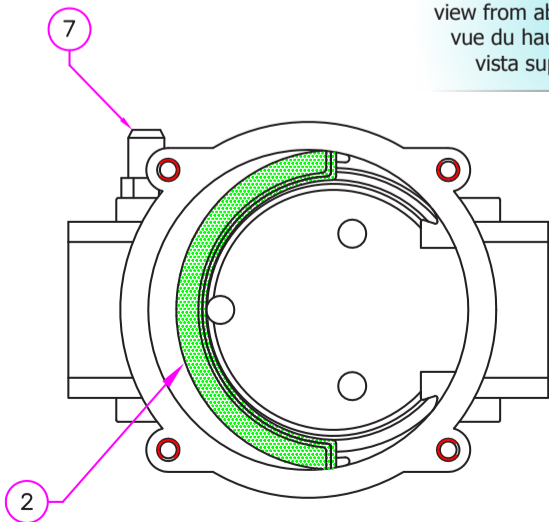

fig. 1, 2 e 3



- 1 - Coperchio / Fondello
- 2 - Organo filtrante
- 3 - Corpo
- 4 - Guide di sistemazione
- 5 - Viti di fissaggio
- 6 - O-Ring di tenuta
- 7 - Presa di pressione

fig. 1, 2 and 3



- 1 - Cover / Bottom
- 2 - Filtering organ
- 3 - Body
- 4 - Slotting guides
- 5 - Fixing screws
- 6 - Seal O-Ring
- 7 - Pressure nipple

fig. 1, 2 et 3



- 1 - Couvercle / Basement
- 2 - Composant filtrant
- 3 - Corps
- 4 - Guides
- 5 - Vis de fixation
- 6 - O-Ring de tenue
- 7 - Prise de pression

fig. 1, 2 y 3



- 1 - Tapa / Fondo
- 2 - Elemento filtrante
- 3 - Cuerpo
- 4 - Guías de ubicación
- 5 - Tornillos de fijación
- 6 - Junta tórica de estanquidad
- 7 - Toma de presión

FM DN 32 ÷ 50

fig. 3

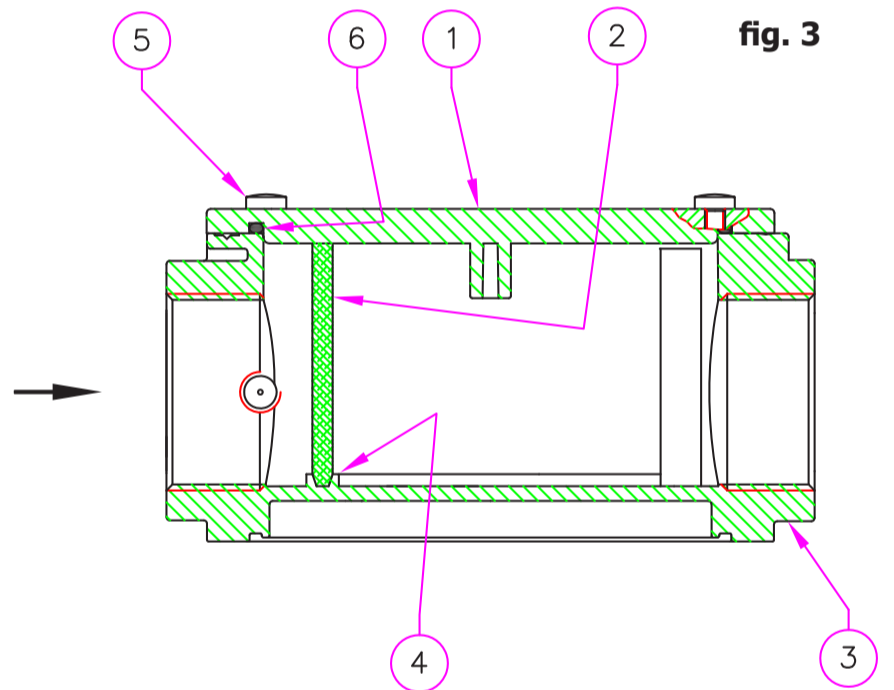

vista dall'alto senza coperchio
view from above without cover
vue du haut sans couvercle
vista superior sin tapa

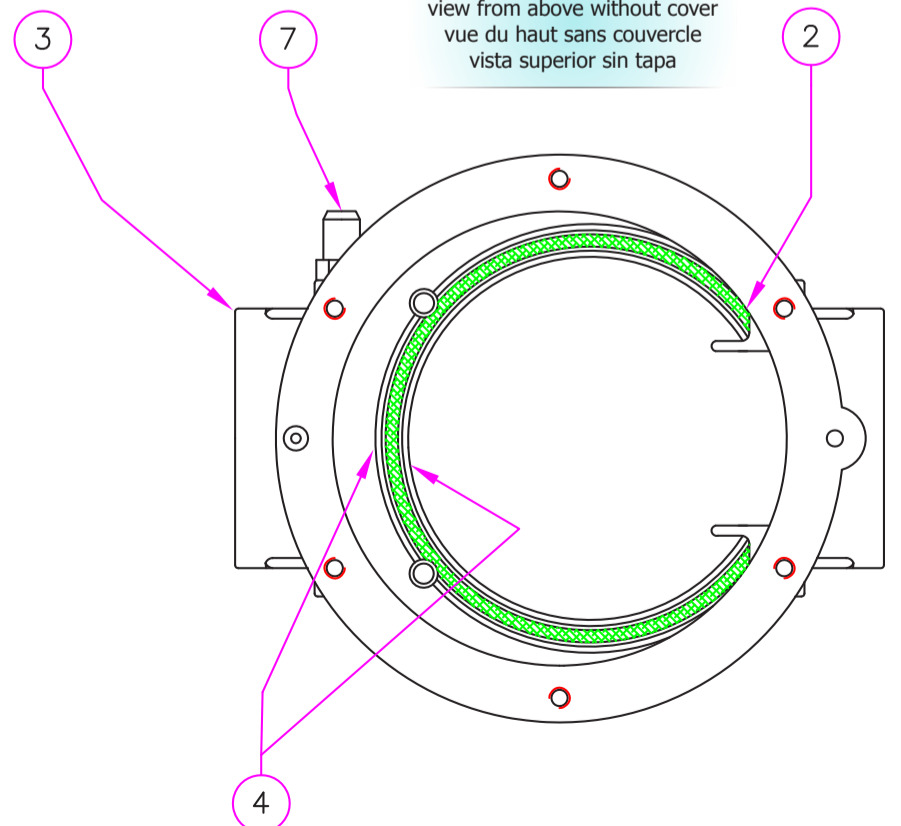

FGM DN 25 ÷ 50

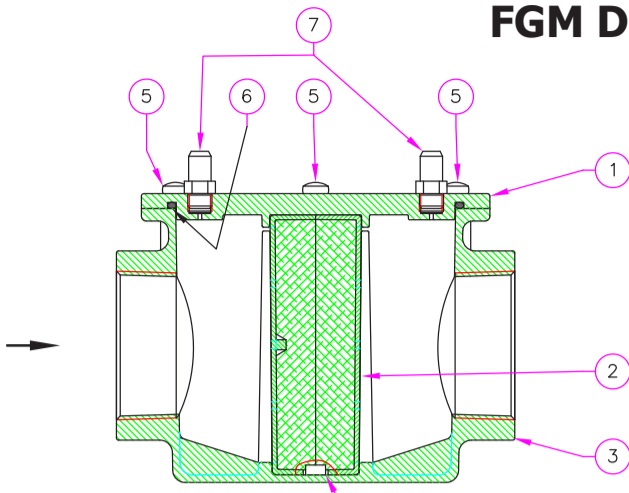
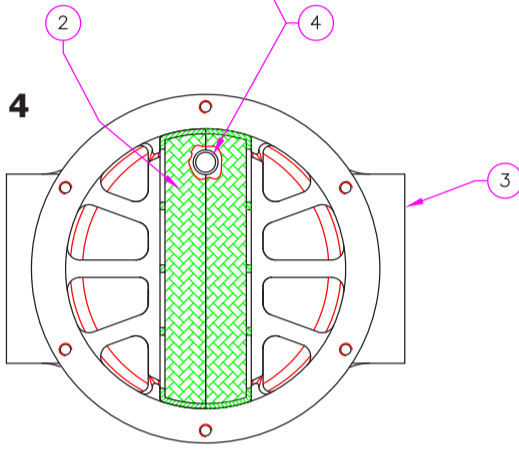

fig. 4



vista dall'alto senza coperchio
view from above without cover
vue du haut sans couvercle
vista superior sin tapa

FM DN 65 ÷ 100

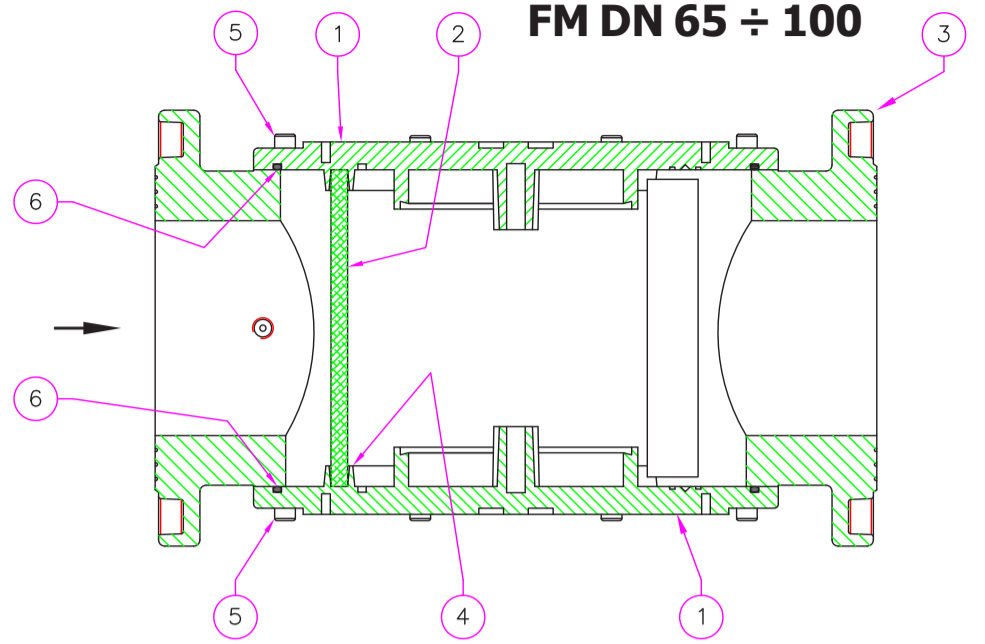
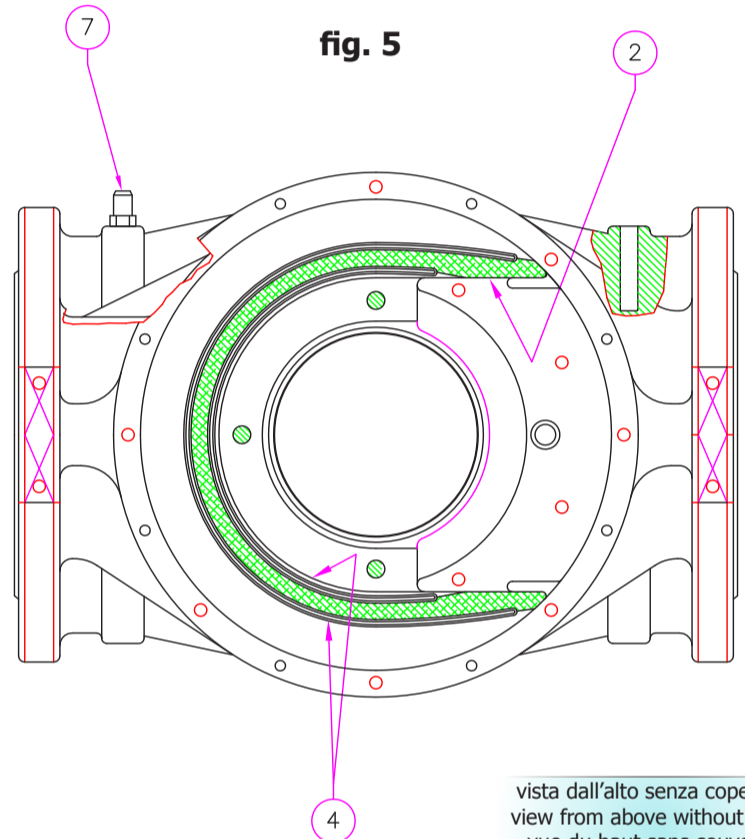

fig. 5



vista dall'alto senza coperchio
view from above without cover
vue du haut sans couvercle
vista superior sin tapa

FM DN 125 ÷ 300

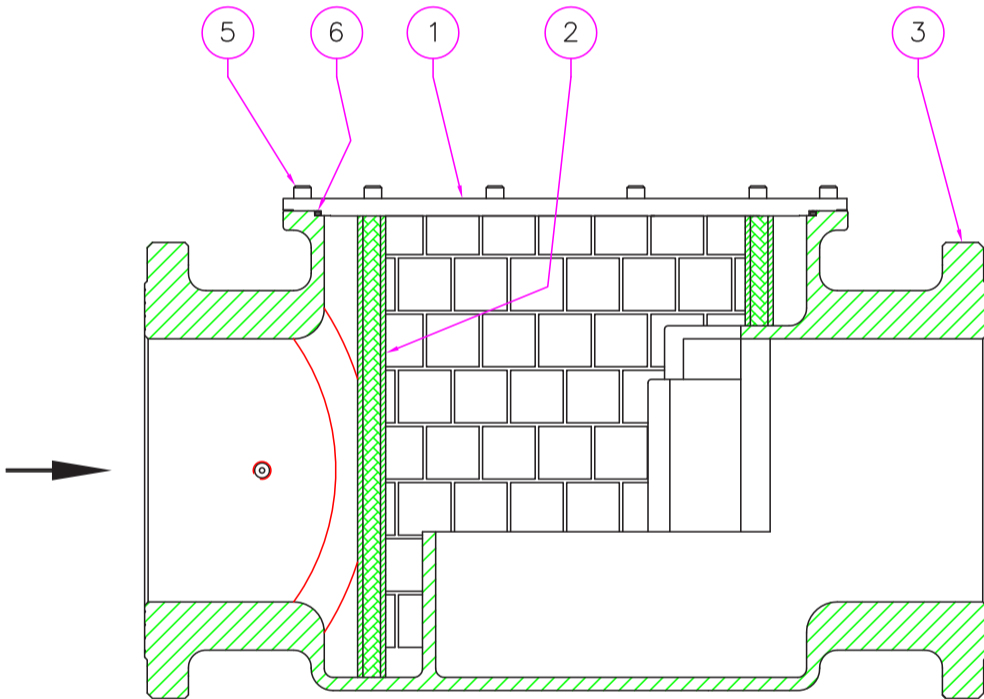
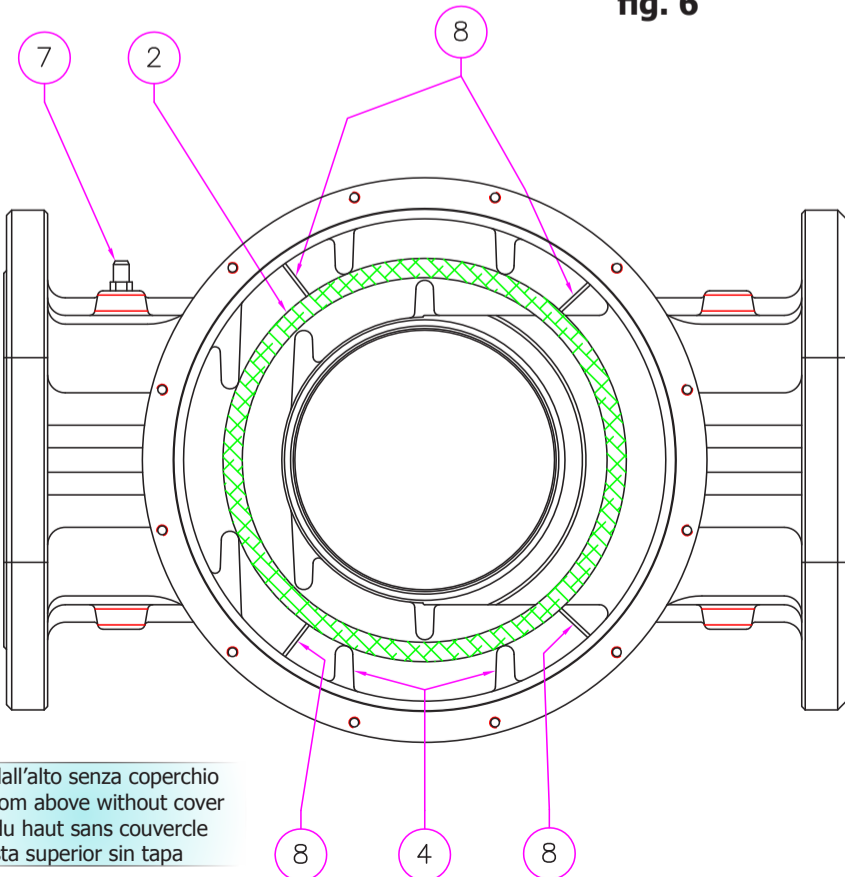

fig. 6



vista dall'alto senza coperchio
view from above without cover
vue du haut sans couvercle
vista superior sin tapa

fig. 4,5 e 6



- 1 - Coperchio / Fondello
- 2 - Organo filtrante
- 3 - Corpo
- 4 - Guide di sistemazione
- 5 - Viti di fissaggio
- 6 - O-Ring di tenuta
- 7 - Presa di pressione
- 8 - Alette speciali

fig. 4, 5 and 6



- 1 - Cover / Bottom
- 2 - Filtering organ
- 3 - Body
- 4 - Slotting guides
- 5 - Fixing screws
- 6 - Seal O-Ring
- 7 - Pressure nipple
- 8 - Special tongues

fig. 4,5 et 6



- 1 - Couvercle / Basement
- 2 - Composant filtrant
- 3 - Corps
- 4 - Guides
- 5 - Vis de fixation
- 6 - O-Ring de tenue
- 7 - Prise de pression
- 8 - Ailettes spéciales

fig. 4,5 y 6



- 1 - Tapa / Fondo
- 2 - Elemento filtrante
- 3 - Cuerpo
- 4 - Guías de ubicación
- 5 - Tornillos de fijación
- 6 - Junta tórica de estanquidad
- 7 - Toma de presión
- 8 - Aletas especiales

**DIAGRAMMA PERDITE DI CARICO FMC - FM - FGM (filtraggio 50 µm) - FMC - FM - FGM PRESSURE DROPS DIAGRAM (filtering 50 µm)
DIAGRAMME PERTES DE CHARGE FMC - FM - FGM (filtrage 50 µm) - DIAGRAMA DE CAUDALES FMC - FM - FGM (filtración 50 µm)**

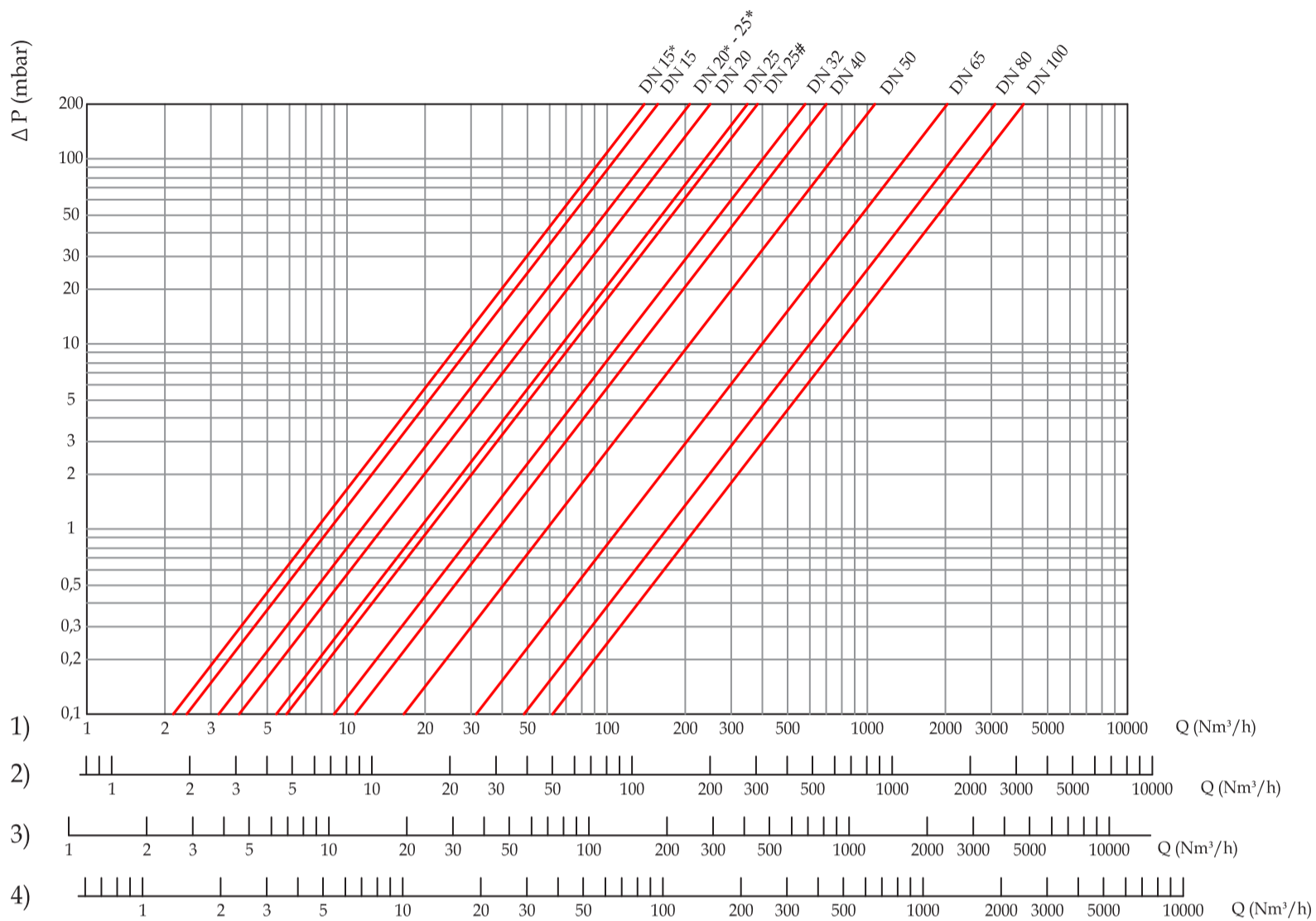



- 1) metano
- 2) aria
- 3) gas di città
- 4) gpl



- 1) methane
- 2) air
- 3) town gas
- 4) lpg



- 1) méthane
- 2) air
- 3) gaz de ville
- 4) gaz liquide



- 1) methane
- 2) aire
- 3) gas de ciudad
- 4) gpl

* versione compact - compact version - version compact - versión compact

attacchi DN 25 con corpo DN 32 - DN 25 connections with DN 32 body - fixations DN 25 avec un corps DN 32 - conexiones DN 25 con cuerpo DN 32

**DIAGRAMMA PERDITE DI CARICO FMC - FM - FGM (filtraggio 20 µm) - FMC - FM - FGM PRESSURE DROPS DIAGRAM (filtering 20 µm)
DIAGRAMME PERTES DE CHARGE FMC - FM - FGM (filtrage 20 µm) - DIAGRAMA DE CAUDALES FMC - FM - FGM (filtración 20 µm)**

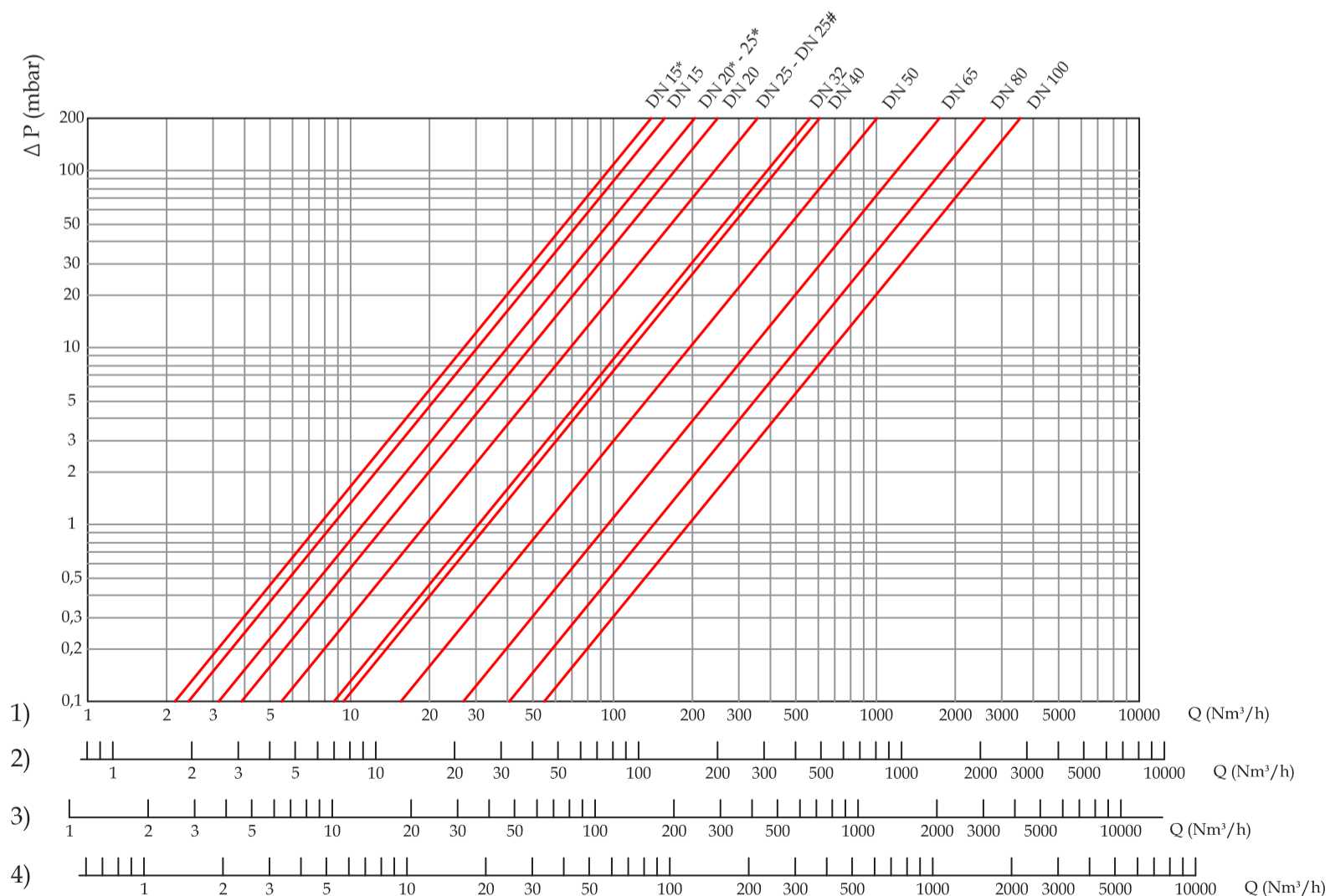





- 1) metano
- 2) aria
- 3) gas di città
- 4) gpl



- 1) methane
- 2) air
- 3) town gas
- 4) lpg



- 1) méthane
- 2) air
- 3) gaz de ville
- 4) gaz liquide





- 1) methane
- 2) aire
- 3) gas de ciudad
- 4) gpl

* versione compact - compact version - version compact - versión compact

attacchi DN 25 con corpo DN 32 - DN 25 connections with DN 32 body - fixations DN 25 avec un corps DN 32 - conexiones DN 25 con cuerpo DN 32

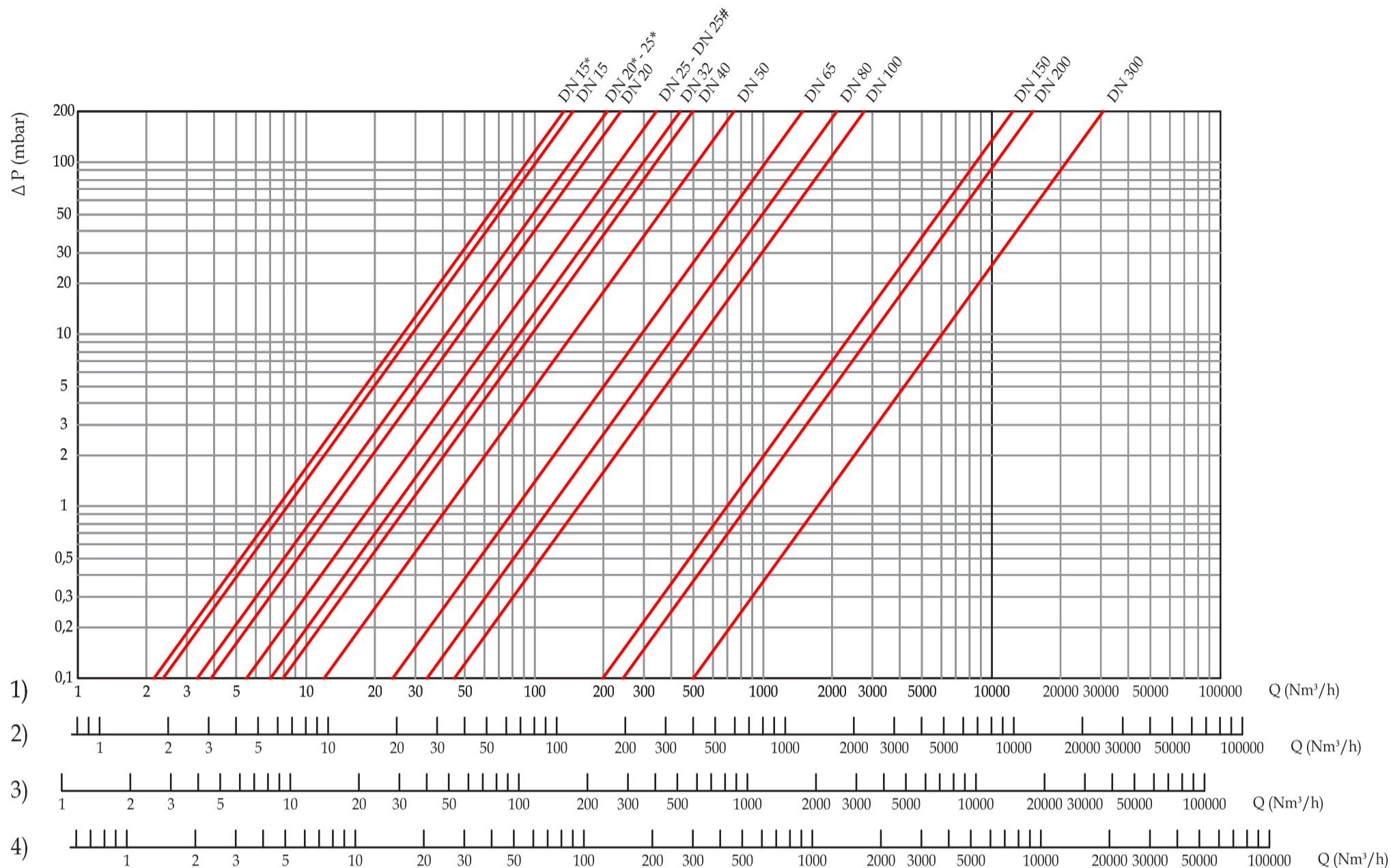
DIAGRAMMA PERDITE DI CARICO FMC - FM (filtraggio 10 µm) - FMC - FM PRESSURE DROPS DIAGRAM (filtering 10 µm)
DIAGRAMME PERTES DE CHARGE FMC - FM (filtrage 10 µm) - DIAGRAMA DE CAUDALES FMC - FM (filtración 10 µm)

1) metano
2) aria
3) gas di città
4) gpl



1) methane
2) air
3) town gas
4) lpg



1) méthane
2) air
3) gaz de ville
4) gaz liquide



1) methane
2) aire
3) gas de ciudad
4) gpl

* versione compact - compact version - version compact - versión compact

attacchi DN 25 con corpo DN 32 - DN 25 connections with DN 32 body - fixations DN 25 avec un corps DN 32 - conexiones DN 25 con cuerpo DN 32

Misure di ingombro in mm Overall dimensions in mm Mesures d'encombrement en mm Dimensiones en mm					DN25M = attacchi DN 25 con corpo DN 32 DN25M = DN 25 connections with DN 32 body DN25M = fixations DN 25 avec un corps DN 32 DN25M = conexiones DN 25 con cuerpo DN 32		
Tipo Type Type Tipo	Attacchi filettati Threaded sizes Fixations filetees Conexiones roscadas	Attacchi flangiati Flanged connections Fixations bridees Conexiones de brida	A	B	Kg		superficie filtrante (mm ²) filtering surface (mm ²) filtre de surface (mm ²) superficie del filtro (mm ²)
FMC	DN 15 (compact)	-	70	63	0,35		3890
FMC	DN 20 (compact)	-	70	63	0,35		3890
FMC	DN 25 (compact)	-	70	63	0,35		3890
FM	DN 15	-	120	72	0,5		4560
FM	DN 20	-	120	72	0,5		4560
FM	DN 25	-	120	72	0,5		4560
FM	DN 25M	-	160	87	1,25		19040
FM	DN 32	-	160	87	1,2		19040
FM	DN 40	-	160	87	1,2		19040
FM	DN 50	-	160	110	1,35		26770
FM	-	DN 25	192	115	3,2		19040
FF	-	DN 32	230	135	2,5		10650
FF	-	DN 40	230	135	2,5		10650
FF	-	DN 50	230	135	2,5		10650
FGM	DN 25M	-	160	135	1,4		10650
FGM	DN 32	-	160	135	1,35		10650
FGM	DN 40	-	160	135	1,35		10650
FGM	DN 50	-	160	135	1,35		10650
FM	-	DN 65	290	180	5,3		39240
FM	-	DN 80	310	195	5,7		39240
FM	-	DN 100	350	211	9,8 (P. max. 2 Bar)	15 (P. max 6 Bar)	76250
FM	-	DN 125	480	302	25		198000
FM	-	DN 150	480	302	26,2		198000
FM	-	DN 200	600	380	50		-
FM	-	DN 300	737	510	90		-

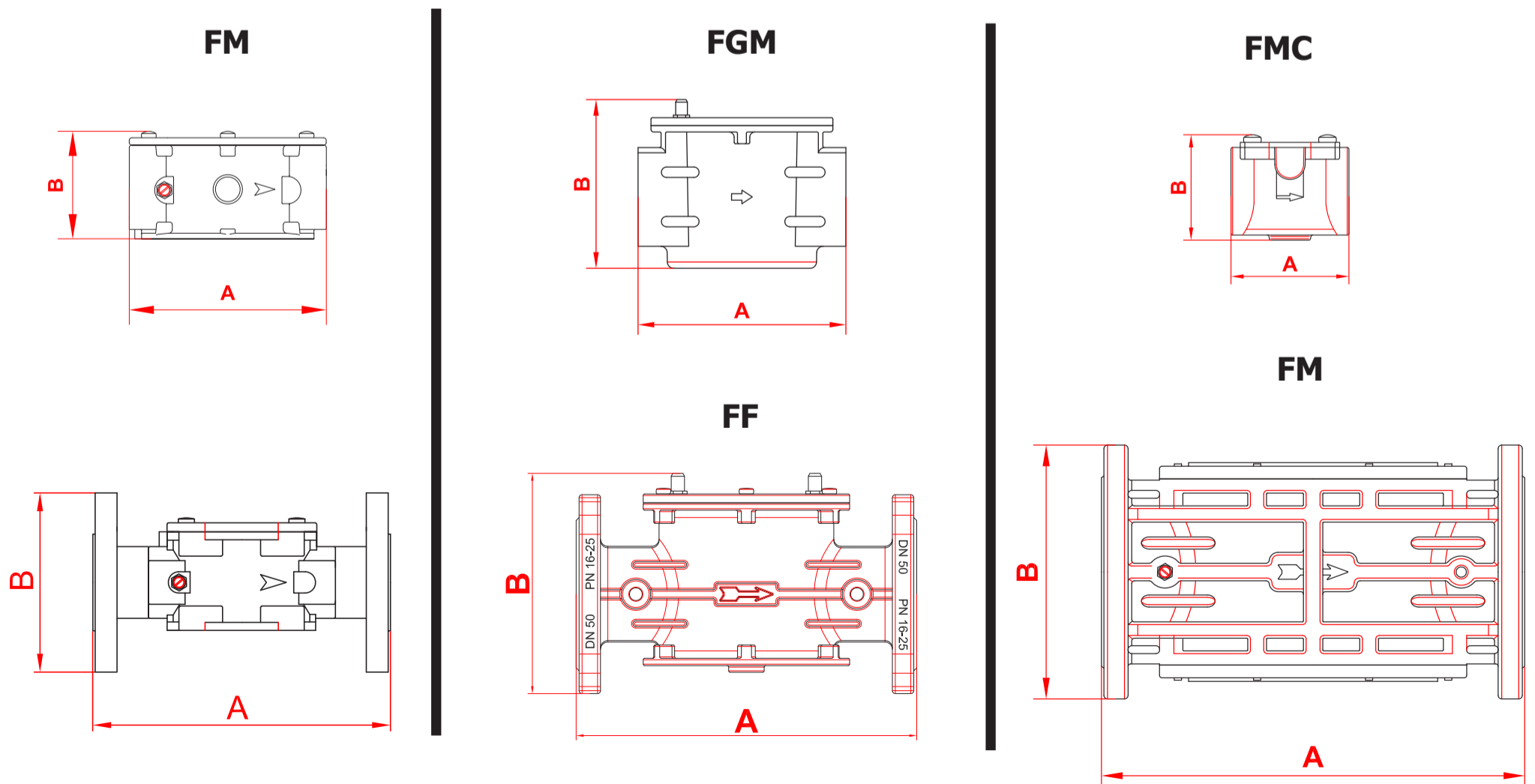

INSTALLAZIONE



Si raccomanda di leggere attentamente il foglio di istruzioni a corredo di ogni prodotto.

ATTENZIONE: le operazioni di installazione/manutenzione devono essere eseguite da personale qualificato.

- E' necessario chiudere il gas prima dell'installazione.
- Verificare che la pressione di linea **NON SIA SUPERIORE** alla pressione massima dichiarata sull'etichetta del prodotto.
- Il filtro è normalmente posizionato a monte di tutti gli organi di regolazione e intercettazione. Deve essere installato con la freccia (in rilievo sul corpo in alluminio o sul coperchio) rivolta verso l'utenza.
- Può essere installato in qualsiasi posizione senza che ne venga pregiudicato il corretto funzionamento. All'esterno del filtro è sistemata una presa di pressione per l'eventuale controllo.
- Durante l'installazione evitare che detriti o residui metallici penetrino all'interno dell'apparecchio.
- Se l'apparecchio è filettato verificare che la lunghezza del filetto della tubazione non sia eccessiva per non danneggiare il corpo dell'apparecchio in fase di avvitamento.
- Se l'apparecchio è flangiato verificare che le controflange di ingresso e uscita siano perfettamente parallele per evitare di sottoporre il corpo a inutili sforzi meccanici, calcolare inoltre lo spazio per l'inserimento della guarnizione di tenuta. Se a guarnizioni inserite lo spazio rimanente è eccessivo non cercare di colmarlo stringendo eccessivamente i bulloni dell'apparecchio.
- In ogni caso dopo l'installazione verificare la tenuta dell'impianto.



INSTALLATION



It is always important to read carefully the instruction sheet of each product.

WARNING: all installation/maintenance work must be carried out by skilled staff.

- The gas supply must be shut off before installation.
- Check that the line pressure **DOES NOT EXCEED** the maximum pressure stated on the product label.
- The filter is normally installed upstream the regulation organs and the interception device. It must be installed with the arrow (on the body valve) towards the user.
- It can be installed in any position without compromising the correct working. Outside the filter there is a checking pressure-tap.
- During installation take care not to allow debris or scraps of metal to enter the device.
- If the device is threaded check that the pipeline thread is not too long; overlong threads may damage the body of the device when screwed into place.
- If the device is flanged check that the inlet and outlet counterflanges are perfectly parallel to avoid unnecessary mechanical stresses on the body of the device. Also calculate the space needed to fit the seal. If the gap left after the seal is fitted is too wide, do not try to close it by over-tightening the device's bolts.
- Always check that the system is gas-tight after installation.



INSTALLATION



Lire attentivement les instructions pour chaque produit.

ATTENTION: les opérations d'installation/entretien doivent être exécutées par du personnel qualifié.

- Fermer le gaz avant l'installation.
- Vérifier que la pression de ligne **NE SOIT PAS SUPÉRIEURE** à la pression maximum déclarée sur l'étiquette du produit.
- Le filtre est normalement situé en amont de tous les organes de réglage et d'arrêt. Il doit être installé avec la flèche (en relief sur le corps ou sur le couvercle) tournée vers le tuyau principal.
- Il peut être installé dans n'importe quelle position sans que son fonctionnement correct soit compromis. A l'extérieur du filtre est installée une prise de pression pour l'éventuel contrôle.
- Pendant l'installation, éviter que des débris ou des résidus métalliques pénètrent dans l'appareil.
- Si l'appareil est fileté, vérifier que le filet de la tuyauterie ne soit pas trop long pour ne pas endommager le corps de l'appareil lors du vissage.
- Si l'appareil est bridé, vérifier que les contre-bridés d'entrée et de sortie soient parfaitement parallèles pour éviter de soumettre le corps à des efforts mécaniques inutiles; par ailleurs, calculer l'espace pour l'introduction du joint d'étanchéité. Si, lorsque les joints sont introduits, l'espace restant est excessif, ne pas essayer de le combler en serrant trop fort les boulons de l'appareil.
- De toute façon, après l'installation vérifier l'étanchéité de l'installation.



INSTALACIÓN



Se recomienda leer atentamente la hoja de instrucciones adjuntas con el producto.

ATENCIÓN. Las operaciones de instalación y mantenimiento deben ser efectuadas por personal cualificado.

- Antes de iniciar las operaciones de instalación es necesario cerrar el gas.
- Verificar que la presión de la línea **NO SEA SUPERIOR** a la presión máxima indicada en la etiqueta del producto.
- El filtro viene normalmente posicionado río arriba de todos los órganos de regulación y interceptación. Debe ser instalado con la flecha (en relieve en el cuerpo de aluminio o en la tapa) hacia el punto de consumo.
- Se puede instalar en cualquier posición sin perjudicar el correcto funcionamiento. Al exterior del filtro está una toma de presión por el eventual control.
- Durante la instalación prestar atención a fin de evitar que detritos o residuos metálicos se introduzcan en el aparato.
- En el caso de aparato roscado será necesario verificar que la longitud de la rosca de la tubería no sea excesiva dado que, durante el enroscado, podrá provocar daños en el cuerpo del aparato mismo.
- En el caso de aparato embreadado, será necesario controlar que las contrabridas de entrada y de salida queden perfectamente paralelas a fin de evitar que el cuerpo quede sometido a fuerzas mecánicas inútiles. Calcular además el espacio para la introducción de la junta de estanqueidad. Si una vez introducidas las juntas el espacio restante es excesivo, no apretar demasiado los pernos del aparato para intentar reducirlo.
- De todas formas, verificar la estanqueidad del sistema una vez efectuada la instalación.



ESEMPIO DI INSTALLAZIONE

1. Valvola a strappo SM
2. Filtro gas serie FM
3. Valvola di blocco MVB/1 MAX o MIN
4. Regolatore gas serie RG/2MC
5. Valvola di sfioro MVS/1
6. Leva comando a distanza valvola a strappo SM

EXAMPLE OF INSTALLATION

1. SM series jerk handle ON/OFF valve
2. FM series gas filter
3. MVB/1 MAX or MIN shut off valve
4. RG/2MC series pressure regulator
5. MVS/1 overflow valve
6. Lever for remote SM ON/OFF valve control

EXEMPLE D'INSTALLATION

1. Soupape à déchirement SM
2. Filtre gaz série FM
3. Soupape de bloc MVB/1 MAX ou MIN
4. Régulateur gaz série RG/2MC
5. Soupape d'effluement MVS/1
6. Levier de comande à distance soupape à déchirement SM

EJEMPLO DE INSTALACIÓN

1. Válvula de corte SM
2. Filtro gas serie FM
3. Válvulas de bloqueo MVB/1 MAX o MIN
4. Regulador gas serie RG/2MC
5. Válvula de alivio MVS/1
6. Palanca para actuación de de la válvula de corte SM

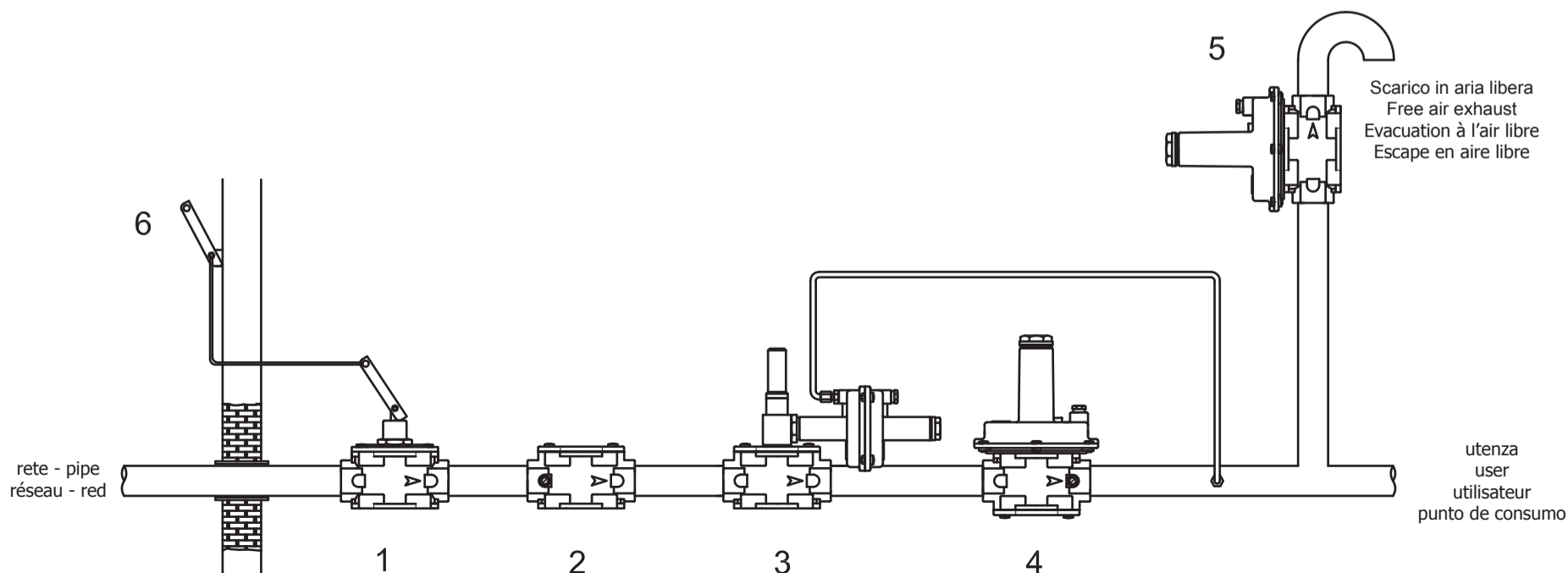

**MANUTENZIONE**

In ogni caso prima di effettuare verifiche interne accertarsi che all'interno dell'apparecchio non vi sia gas in pressione.

Togliere il coperchio (1) svitando le viti di fissaggio (5). Smontare la cartuccia filtrante (2), pulirla con acqua e sapone, soffiare con aria compressa (o sostituirla se necessario) e rimontarla nella posizione iniziale controllando che sia sistemata tra le apposite guide (4) controllando che non ostacoli il montaggio del coperchio (1).

Infine rimontare il coperchio (1) facendo attenzione che l'O-Ring (6) sia sistemato nell'apposita cava.



Le suddette operazioni devono essere eseguite esclusivamente da tecnici qualificati.

**SERVICING**

In all cases, before performing any internal checks make sure that there is no pressurised gas inside the device.

Remove cover (1) and unscrew the fixing screws (5). Disassemble the filter cartridge (2), clean with soap and water, blow with compressed air (or substitute if necessary) and re-assemble in the original position checking that it is properly positioned in the guides (4), and check that it does not prevent assembly of the cover (1).

Lastly re-assemble the cover (1) making sure that the O-ring (6) is in the correct position.



The above-said operations must be carried out only by qualified technicians.

**MANUTENTION**

Avant de faire des vérifications internes, s'assurer qu'il n'y ait pas de gaz sous pression dans l'appareil.

Enlever le couvercle (1) en dévissant les vis de fixation (5). Démontez la cartouche filtrante (2), la nettoyer avec de l'eau et du savon et y souffler de l'air comprimé (ou la remplacer si nécessaire); la remonter dans la position initiale en contrôlant qu'elle soit bien placée entre les guides (4) et qu'elle ne gêne pas le montage du couvercle (1).

Remonter le couvercle (1) en faisant attention que le joint torique (6) soit placé dans son logement.



Les opérations mentionnées ci-dessus doivent être exécutées exclusivement par des techniciens qualifiés.

**MANTENIMIENTO**

De todas formas, antes de efectuar verificaciones internas, controlar que en su interior no haya gas en presión.

Quitar la tapa (1) desenroscando los tornillos de fijación (5). Desmontar el cartucho filtrante (2), lavarlo con agua y jabón y soplarlo con aire comprimido, o bien sustituirlo si es necesario, y volver a montarlo en su posición original, controlando que quede ubicado entre las guías correspondientes (4) y que no impida la colocación de la tapa (1).

Por último, colocar la tapa (1) nuevamente prestando atención en que la junta tórica de cierre (6) quede ubicada en la ranura correspondiente.



Las operaciones antes indicadas deben ser ejecutadas únicamente por técnicos cualificados.