

Air Vent Valves

Air vent valves with float

Technical Data Sheet



Description

The valves DUOVENT **DUO, DUO/R Series**, INTERVENT **INT, INT/R, INT/AV15 Series**, FLOATVENT **2161C Series**, MICROVENT **MKV, MKVR, MKL, MKLR Series**, HYBRIVENT **MHV, MHVR, MHL, MHLR Series** and MAXIVENT **MXV Series** are automatic and/or manual devices for discharging air from heating and air-conditioning systems. These devices should be used in close loop hydronic application only.

DUO

DUOVENT

Automatic and manual air vent valve with removable cover for inspection. Body and cover in brass CW617N. Corrosion-resistant polyethylene float. PN12.

Maximum working pressure: 12 bar.

Maximum working temperature: 115°C. Automatic venting capacity at 3 bar: 20 l/min.

Manual venting capacity at 3 bar: 100 l/min.

Also suitable for water containing additive (glycol up to 50%).



Type	Part. no.	DN	Weight (g)	Box
DUO10	0248210	3/8"	140	1
DUO-K10	0248210-K10	3/8"	1450	10
DUO15	0248215	1/2"	140	1
DUO15-K10	0248215-K10	1/2"	1450	10
DUO20	0248220	3/4"	140	1
DUO20-K10	0248220-K10	3/4"	1450	10

DUO/R

DUOVENT WITH RIA.

Air vent valve like DUO but complete with automatic shut-off valve RIA.



Type	Part. no.	DN	Weight (g)	Box
DUO10.R10	0248310	3/8"	165	1
DUO10.R10-K10	0248310-K10	3/8"	1700	10
DUO10.R15	0248311	1/2"	185	1
DUO10.R15-K10	0248311-K10	1/2"	1900	10

INT

NEW INTERVENT.

Automatic air vent valve with removable cover for inspection. Body and cover in brass CW617N. Corrosion-resistant polyethylene float. PN12. Maximum working pressure: 12 bar. Maximum working temperature: 115°C.

Also suitable for water containing additive (glycol up to 50%).



Type	Part. no.	DN	Weight (g)	Box
INT10	0248010	3/8"	140	1
INT10-K10	0248010-K10	3/8"	1450	10
INT15	0248015	1/2"	140	1
INT15-K10	0248015-K10	1/2"	1450	10
INT20	0248020	3/4"	140	1
INT20-K10	0248020-K10	3/4"	1450	10

INT/R

NEW INTERVENT WITH RIA.

Automatic air vent valve like INT but complete with automatic shut-off valve RIA.



Type	Part. no.	DN	Weight (g)	Box
INT10.R10	0248110	3/8"	165	1
INT10.R10-K10	0248110-K10	3/8"	1700	10
INT10.R15	0248111	1/2"	185	1
INT10.R15-K10	0248111-K10	1/2"	1900	10

INT/AV15



NEW INTERVENT ELBOW MODEL

Automatic air vent valve with removable cover for inspection and lateral connection. Body and cover in brass CW617N. Corrosion-resistant polyethylene float. PN12.

Maximum working pressure: 12 bar. Maximum working temperature: 115°C. Also suitable for water containing additive (glycol up to 50%).

Type	Part. no.	DN	Weight (g)	Box
INT10.AV15	0248016	1/2"	145	1
INT10.AV15-K10	0248016-K10	1/2"	1500	10

2161C



FLOATVENT

Vertical automatic air vent valve. **Pre-sealed with O-ring.** Suitable for installation on the head connections of coplanar manifolds. CW617N brass body. PN10. Maximum temperature: 110°C.

Type	Part No.	DN	Weight (g)
2161C	2161C38	3/8"	135
2161C	2161C12	1/2"	150
2161C	2161C34	3/4"	160
2161C	2161C1	1"	170

MKV



MICROVENT

Vertical automatic air vent valve. CW617N brass body and cover. Pre-sealed with O-ring. PN12. Maximum temperature: 110°C. Also suitable for water with additive (glycol up to 50%).

Type	Part No.	DN	Weight (g)
MKV	0251210	3/8"	140

MKVR



MICROVENT

MKV Series vertical automatic air vent valve with **pre-sealed** automatic shut-off valve.

Type	Part No.	DN	Weight (g)
MKVR	0251310	3/8"	165

MKL



MICROVENT

Lateral automatic air vent valve. CW617N brass body and cover. **Pre-sealed** with O-ring. PN12. Maximum temperature: 110°C. Also suitable for water with additive (glycol up to 50%).

Type	Part No.	DN	Weight (g)
MKL	0252210	3/8"	140



MKLR

MICROVENT

MKL Series lateral automatic air vent valve with **pre-sealed** automatic shut-off valve.

Type	Part No.	DN	Weight (g)
MKLR	0252310	3/8"	165



MHV

HYBRIVENT VERTICAL

Automatic vertical air vent valve. Body in brass CW617N. Cover in composite material. Sealed with O-Ring. PN12. Maximum working pressure: 10bar. Maximum working temperature: 110°C. Also suitable for water containing additive (glycol up to 50%).

Type	Part number	DN	Weight (g)	Box
MHV10	0246010	3/8"	80	1
MHV10-K10	0246010-K10	3/8"	850	10



MHV/R

HYBRIVENT VERTICAL WITH RIA

Automatic vertical air vent valve like MHV Series with automatic sealed shut-off valve.

Type	Part number	DN	Weight (g)	Box
MHV10.R10	0246110	3/8"	105	1
MHV10.R10-K10	0246110-K10	3/8"	1200	10
MHV10.R15	0246111	1/2"	125	1
MHV10.R15-K10	0246111-K10	1/2"	1400	10



MHL

HYBRIVENT HORIZONTAL

Automatic side air vent valve. Body in brass CW617N. Cover in composite material. Sealed with O-Ring. PN12. Maximum working pressure: 10 bar. Maximum working temperature: 110°C. Also suitable for water containing additive (glycol up to 50%).

Type	Part number	DN	Weight (g)	Box
MHL10	0247010	3/8"	80	1
MHL-K10	0247010-K10	3/8"	850	10



MHL/R

HYBRIVENT HORIZONTAL WITH RIA

Automatic side air vent valve like MHL Series with automatic sealed shut-off valve.

Type	Part number	DN	Weight (g)	Box
MHL10.R10	0247110	3/8"	105	1
MHL10.R10-K10	0247110-K10	3/8"	1200	10
MHL10.R15	0247111	1/2"	125	1
MHL10.R15-K10	0247111-K10	1/2"	1400	10



MXV

MAXIVENT

High-flow automatic air vent valve. Equipped with manual vent valve. Cast iron body and cover with epoxy paint finish. PN12
Maximum operating temperature: 100°C. 3/8" F air outlet connection.

Type	Part No.	DN	Weight (g)
MXV	0253020	3/4"	4380
MXV	0253025	1"	4440
MXV	0253032	1.1/4"	4400



2311C

CHECKVENT

Pre-sealed check valve for vertical automatic air vent valve P/N 2161C38.

Type	Part No.	DN	Weight (g)
2311C	2311C38	3/8"	25



RIA

Automatic shut-off valve for automatic air vent valves **INT, DUO, MKV, MKL, MHV, MHL Series** with device for quick and total drainage of water from the valve.

Type	Part. no.	DN	Weight (g)
RIA	0259010	3/8" x 3/8"	25
RIA	0259016	3/8" x 1/2"	45
RIA	0259015	1/2" x 1/2"	

Application

These devices are used in all traditional heating systems (independent, central, radiant panel, etc.) for discharging air during the filling phase and the air released into the water during the heating phase, which obstructs the normal circulation of the heat carrier fluid above all at the points where it circulates at a low speed (heat emitters), thus reducing their thermal efficiency.

The air vent valves allow the air to be discharged at the points of the system where it accumulates (distribution manifolds, tops of the risers or directly in the boiler).

Operation

The automatic operation of the air vent valves is based on a float system ensuring tight seal: valve opening and closing is determined by the float movement (up-down).

When there is air in the valve, the force of the float weight acts on the lever which is integral with the plug, thus causing it to move down. In such situation the seat is free and allows the air to be vented outside.

When filling the system with water, the air entrapped in the water circuit is pushed towards the outside via the valves. As soon as all the entrapped air is discharged, the water, entering the tank, pushes the float up. Consequently the lever moves the plug to press against the seat thus ensuring tight sealing of the system, thus preventing the heat carrier fluid from flowing out. The design feature of this device is that it enables air to be discharged from the system automatically while it is being emptied. **2311C Series** or **RIA Series** check valves may be used to carry out maintenance work while the system is pressurized.

The operation of the check valve is based on a spring-activated device, sensitive to the pressure of the system, which ensures a seal by means of O-Rings made of EPDM when there is no air vent valve.

The reliability of the air vent valves is ensured by a series of tests carried out on 100% of products to check that the body and its components are watertight.

DUOVENT

In addition to its automatic air venting feature, the **DUOVENT, DUO, DUO/R Series**, valve is provided with a device allowing manual air venting.

The manual air vent device offers the following advantages:

- a) it allows checking the valve for correct operation
- b) it allows reducing times for discharging air from the system by increasing the discharge flow rate
- c) easier cleaning of the orifice by forcing water to flow through it.

Manual venting is actuated by pushing down mobile plug (5); this can be done by exerting a pressure on the surface, for example with a screw driver. Such operation shifts mobile plug (5) to a position lower than the seat, thus allowing air and/or water to evacuate

DUOVENT- DUO

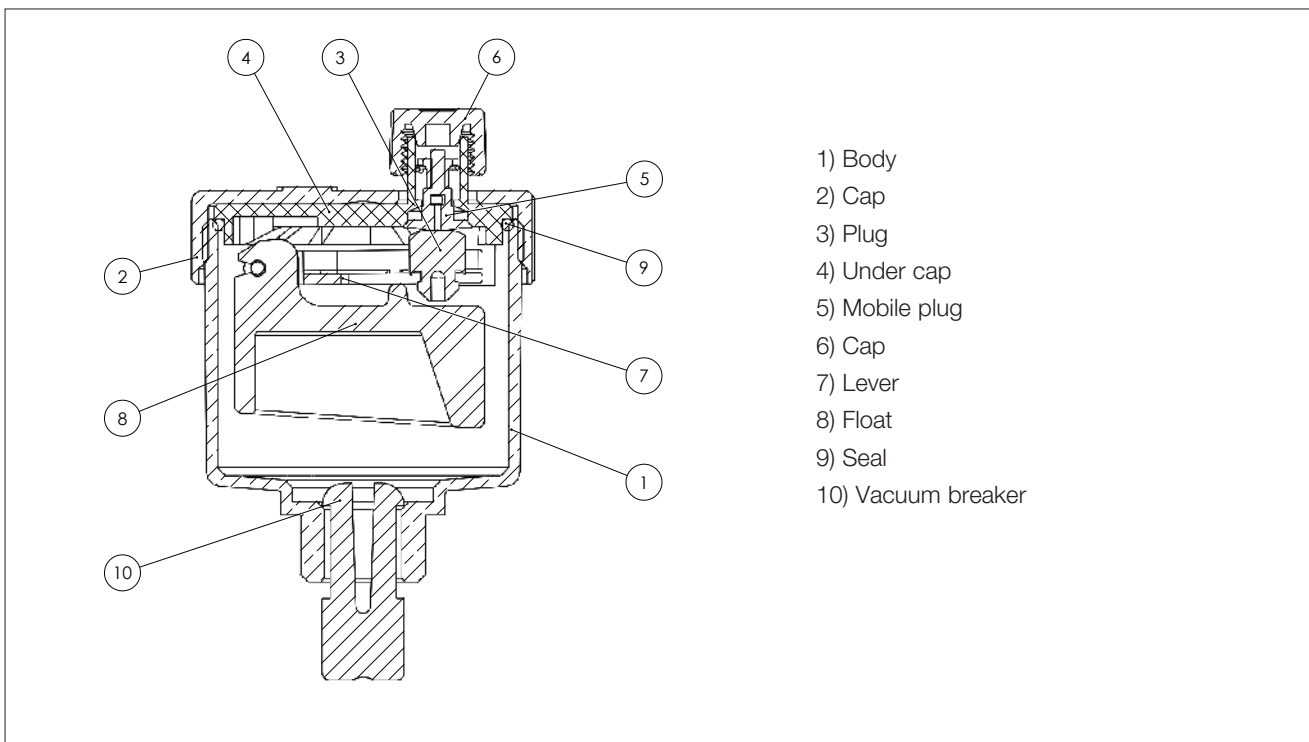

Technical features

Maximum pressure	12 bar
Maximum working pressure	12 bar
Maximum working temperature	115°C

Design features

Body	Brass CW617N
Cover	Brass CW617N
Plug	EPDM rubber
Cap	Polyamide
Lever	Polyacetal
Float	High density expanded polyethylene
Seal	NBR rubber
Connections	G3/8, G1/2, G3/4 ISO 228/1
Under cap	Polyamide

NEW INTERVENT - INT

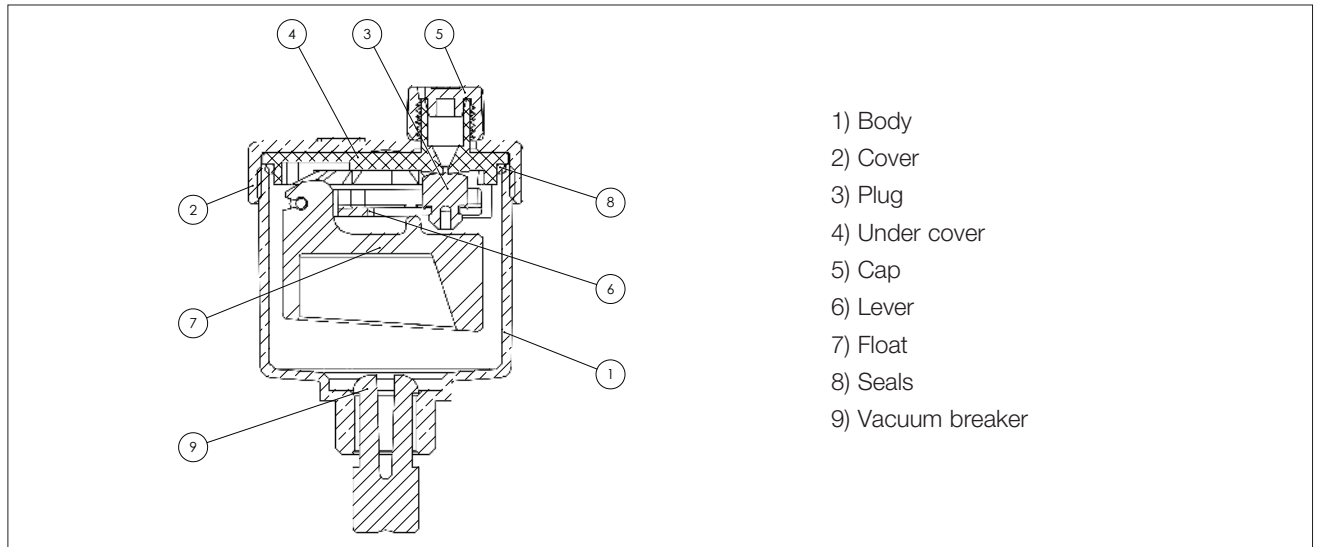

NEW INTERVENT- INT/AV15

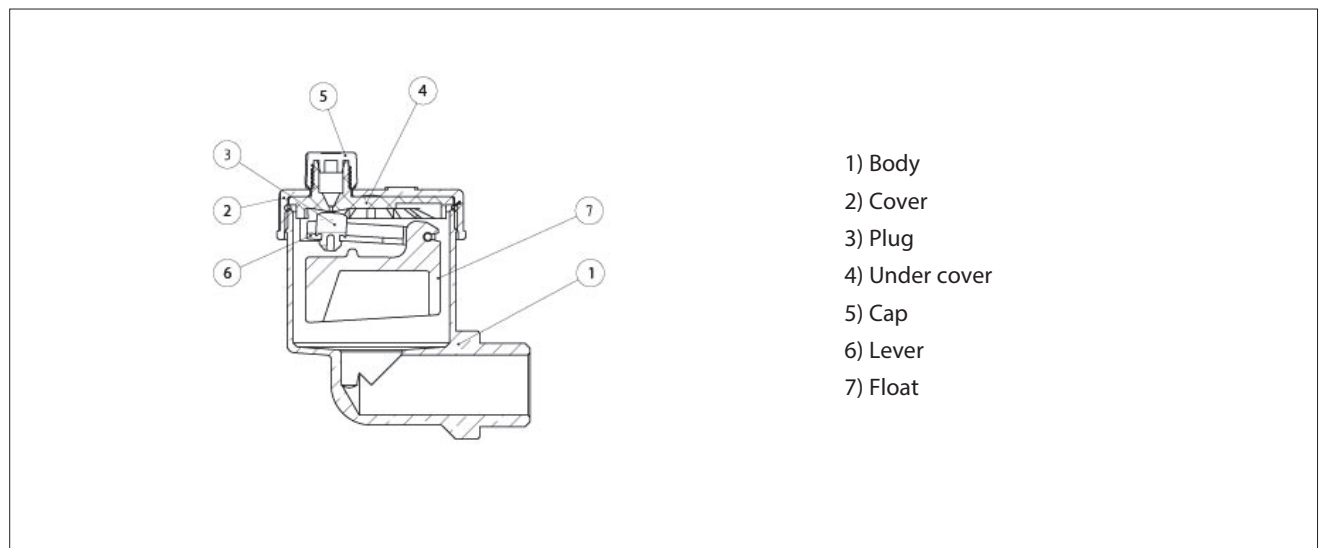

Technical features

Maximum pressure	12 bar
Maximum working pressure	12 bar
Maximum working temperature	115°C

Design features

Body	Brass CW617N
Cover	Brass CW617N
Lever	Polyacetal
Float	High density expanded polyethylene
Plug	EPDM rubber
Seal	NBR rubber
Cap	Polyamide
Connections	G1/2 ISO 228/1
Under cap	Polyamide

FLOATVENT - 2161C

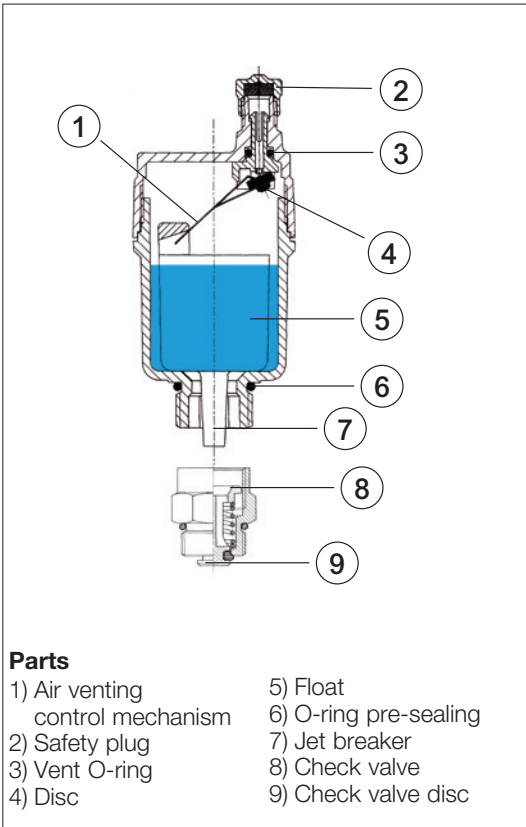

Technical features	
Minimum operating pressure	0.1 bar
Maximum operating pressure	10 bar
Maximum operating temperature	115°C
Usable fluids	water, including with glycol ≤ 50%

Features	
Valve body	CW617N
Float	stabilised polypropylene
O-ring seal	EPDM
Disc	silicone rubber
Control mechanism	stainless steel
O-ring pre-sealing	EPDM
Retaining spring	stainless steel
Retaining disc	PA with fibreglass
Vacuum breaker	polyacetal
Connections	G3/8, G1/2, G3/4, G1 DIN-ISO 228/1

MICROVENT

MICROVENT MKV, MKVR, MKL and MKLR Series valves are equipped with a vacuum breaker, in the vicinity of the threaded connection, designed to improve the air venting characteristics. The vacuum breaker is not fitted if the **MICROVENT** valve is supplied with an **RIA Series** shut-off valve, as the latter is already equipped with a vacuum breaker.

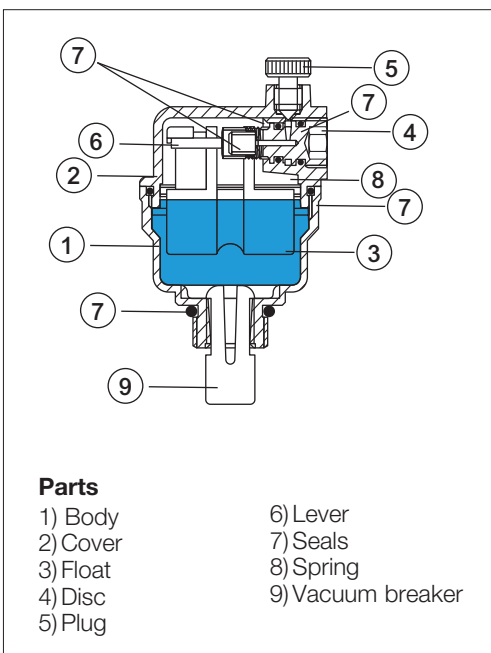

Technical features	
Maximum pressure	12 bar
Maximum operating pressure	bar
Maximum operating temperature	110°C

Features	
Body	CW617N brass
Cover	CW617N brass
Float	high-density expanded polythene
Disc	polyphenylene oxide
Plug	fibreglass-reinforced polyphenylene oxide
Lever	fibreglass-reinforced polyphenylene oxide
Seals	NBR
Spring	stainless steel
Vacuum breaker	polyacetal
Connections	G3/8, G1/2 ISO 228/1

HYBRIVENT

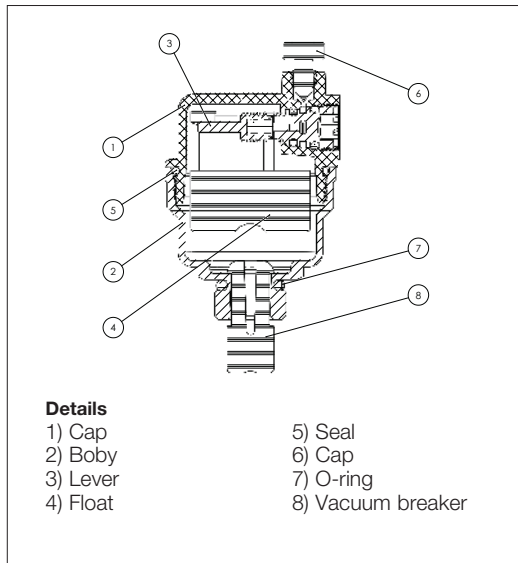

Technical features

Maximum pressure	12 bar
Maximum working pressure	bar
Maximum working temperature	110°C

Design features

Body	Brass CW617N
Cover	Polyamide
Float	High density expanded polyethylene
Plug	Polyphenylene oxide
Cap	Polyphenylene oxide, reinforced glass fiber
Lever	Polyphenylene oxide, reinforced glass fiber
Seal	NBR rubber
Spring	Stainless steel
Vacuum breaker	Polyacetal
Connections	G3/8, G1/2 ISO 228/1

MAXIVENT

Due to its considerable size, the **MAXIVENT MXV Series** air vent valve is used for automatically venting air from large water distribution pipes (e.g. distribution manifolds in the central system, on risers) and in all cases where large quantities of air have to be removed from the system. **MAXIVENT** is also equipped with a manual air vent valve.

Technical features

Maximum discharge pressure	6 bar
Maximum operating pressure	12 bar
Minimum sealing pressure	0.1 bar
Maximum operating temperature	100°C

Features

Body	GJS-400-15 cast iron entirely coated with epoxy resin
Cover	GJS-400-15 cast iron entirely coated with epoxy resin
Manual vent valve	chrome-plated brass
Lever	stainless steel
Disc	NBR
Float	high-density expanded polythene
Seals	NBR
Cap	brass
Inlet connection	F 3/4" - 1" - 1 1/4" DIN-ISO 228/1
Outlet connection	F 3/8" DIN-ISO 228/1 in brass

Charts

DUOVENT

Air discharge rate - Operating pressure
(comparison between manual and automatic venting)

The following diagram shows the automatic and manual venting curves in relation to pressure, assuming a manual plug movement of 1.5 mm. It is clear that the manual venting allows an appreciable increasing in the discharge rate of DUOVENT.

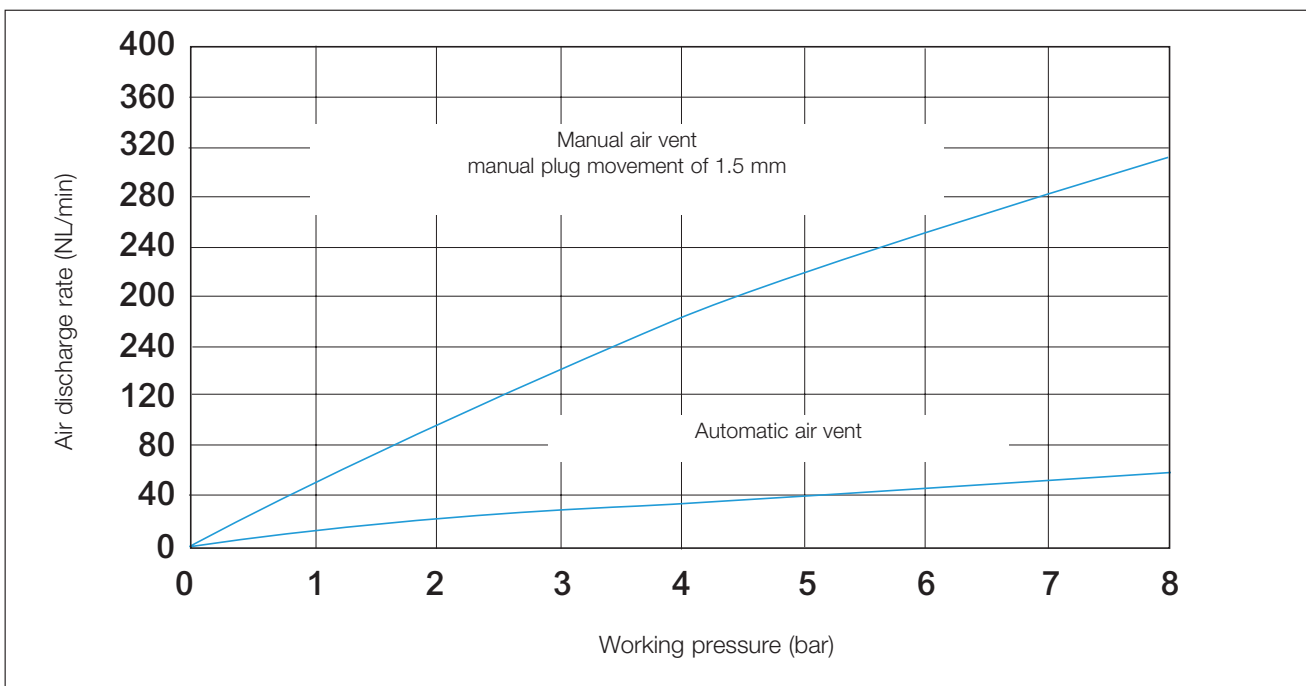
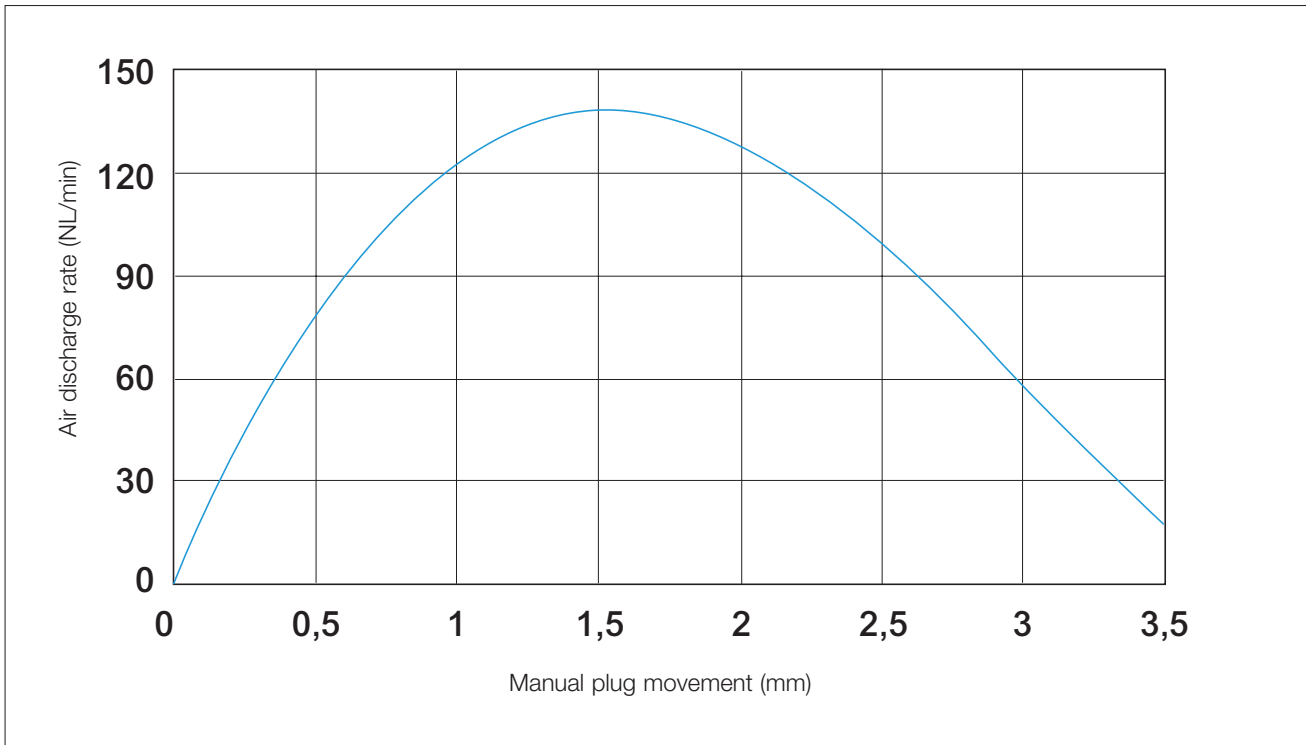

NEW INTERVENT

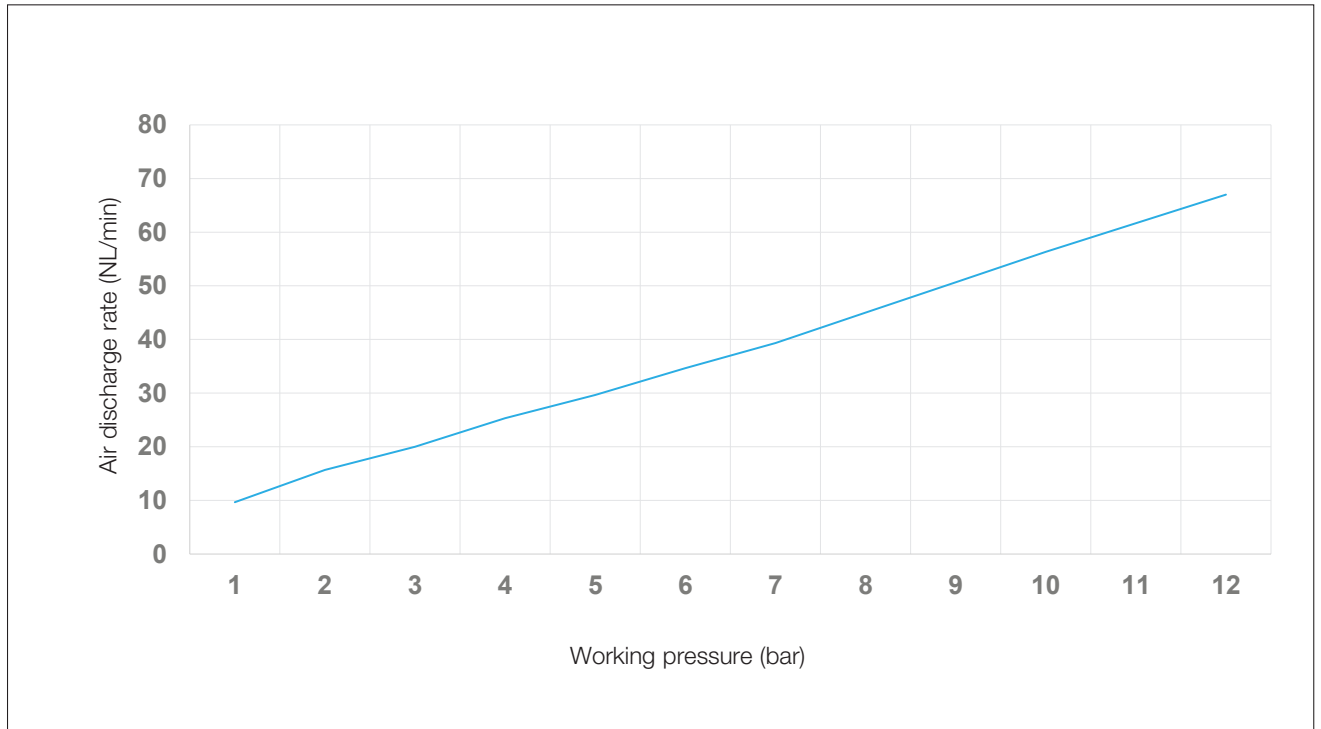

FLOATVENT - 2161C

Discharge capacity

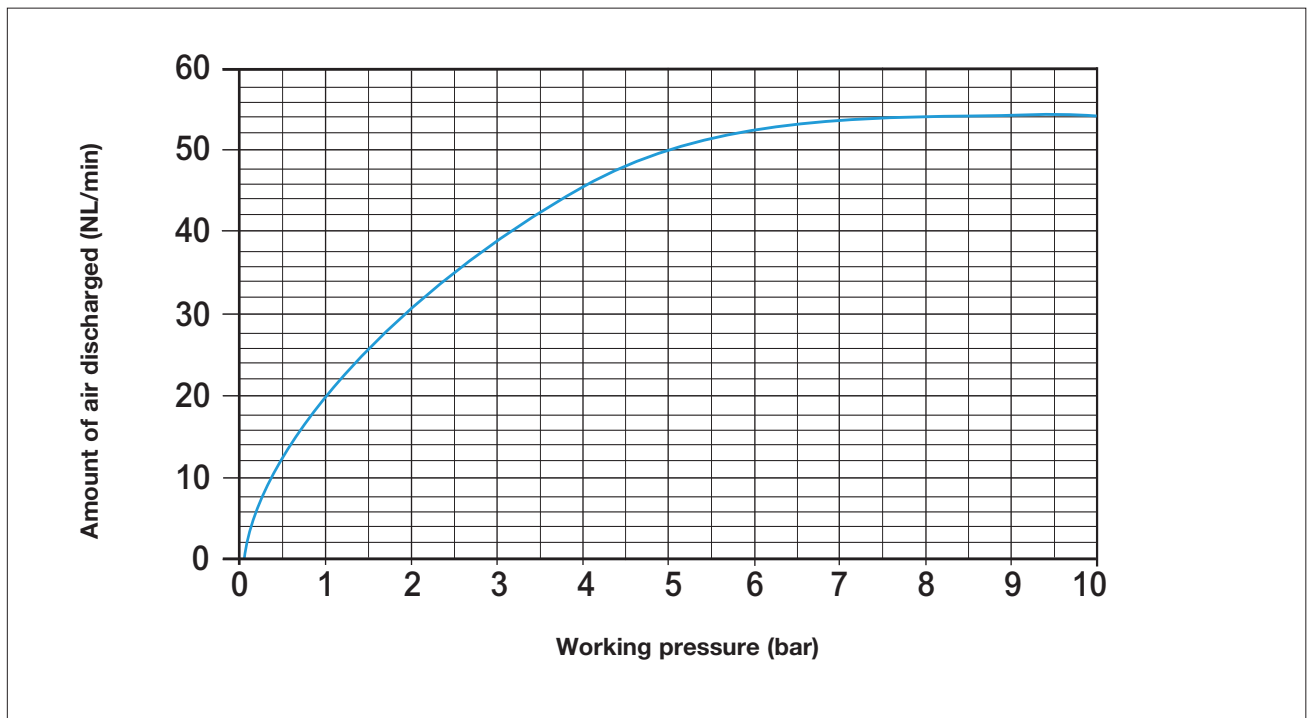

Suction capacity

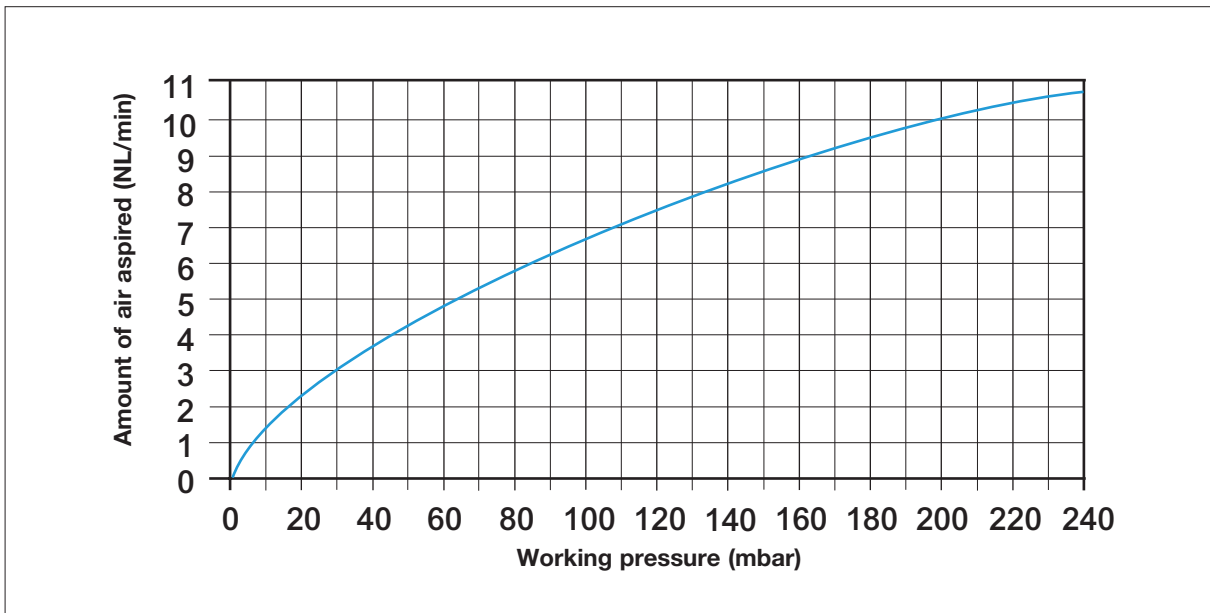

MICROVENT

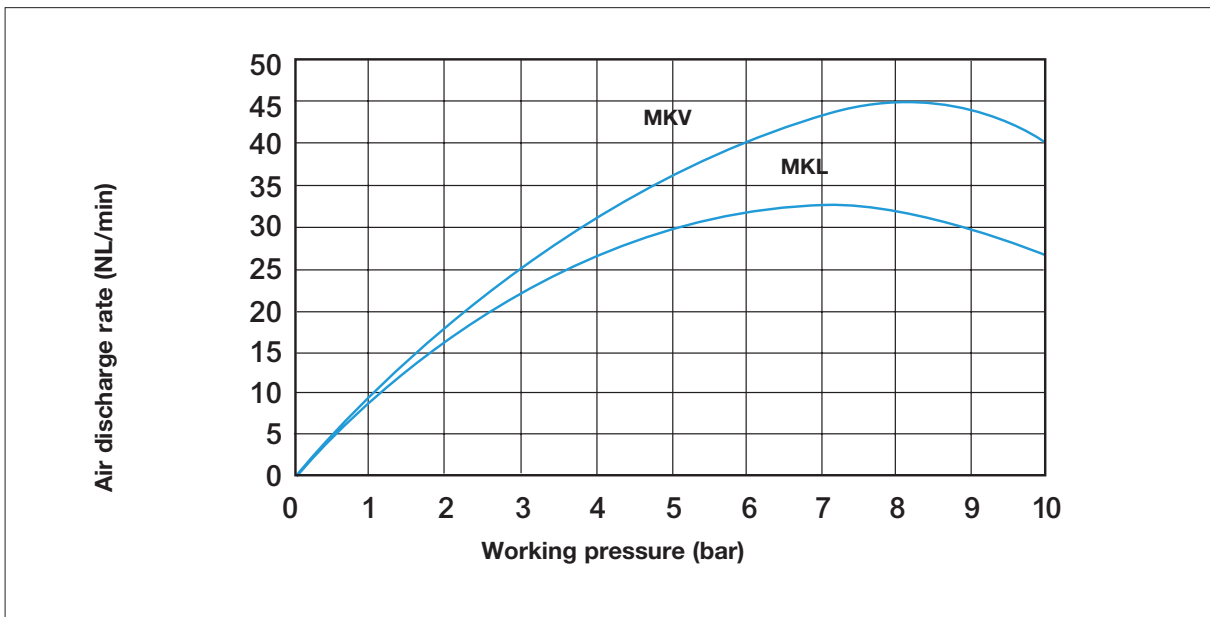

HYBRIVENT

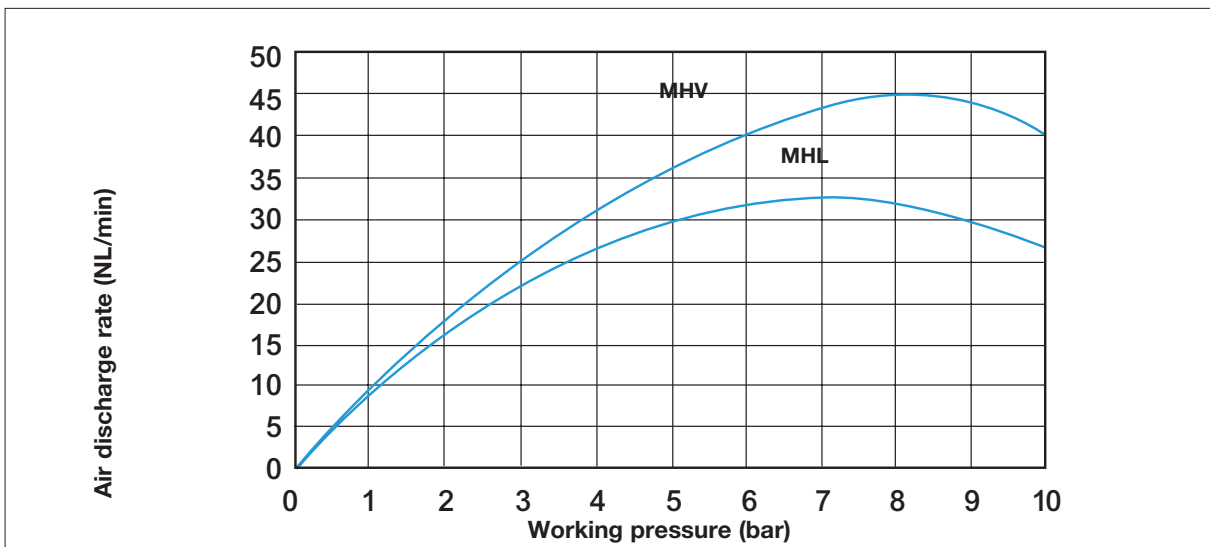

MAXIVENT

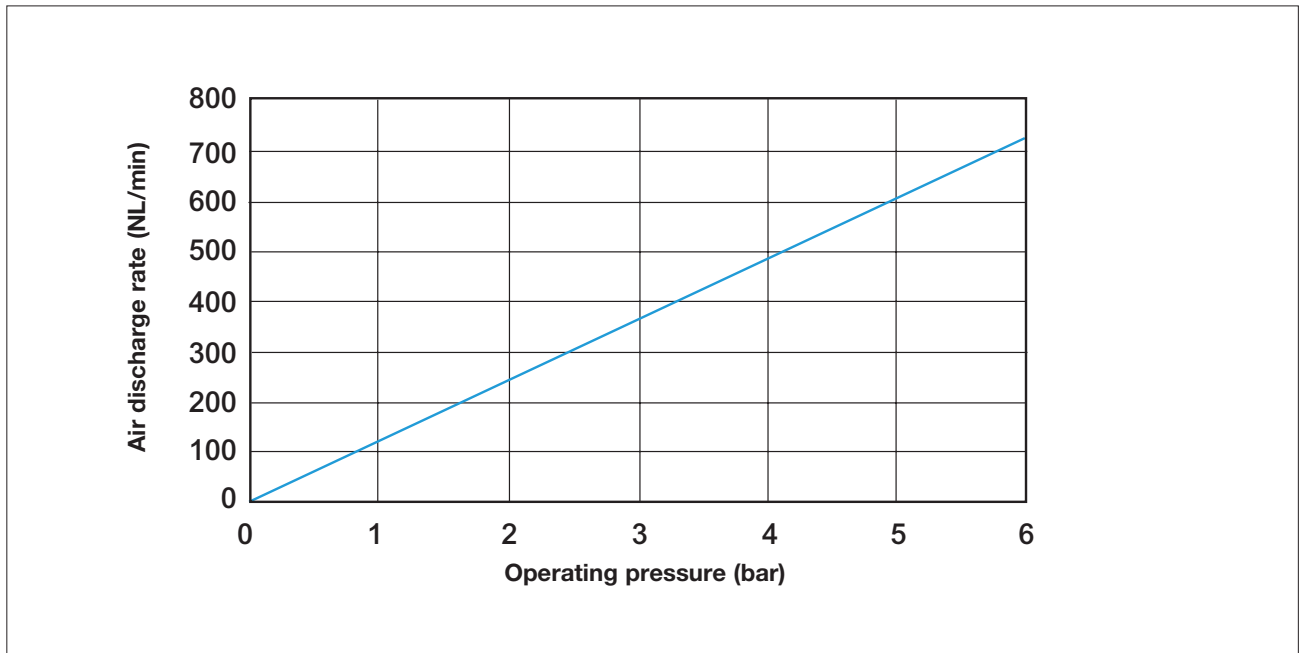

Installation

The **DUOVENT, NEW INTERVENT, FLOATVENT, MINIVENT, HYBRIVENT** and **MAXIVENT Series** air vent valves are normally installed:

- at the top of risers in heating systems with a closed expansion vessel;
- on distribution manifolds;
- directly in the boiler.

In order to ensure maximum air venting efficiency, it is advisable to install the valves in those points where water speed is relatively low. After installation, in order to allow perfect air venting, unscrew the protective cap by at least two turns (such condition ensures the vent characteristics as given in the previous diagram).

When it is necessary to mount a **DUOVENT, NEW INTERVENT, MINIVENT** or **HYBRIVENT** valve provided with vacuum breaker tongue on a **RIA** shut-off valve, merely lift out the tongue with two fingers.

Maintenance

Normally the **DUOVENT, NEW INTERVENT, FLOATVENT, MINIVENT, HYBRIVENT** and **MAXIVENT Series** valves do not require maintenance.

The valves may be inspected by unscrewing the cover from the tank. A tight seal between the tank and cover is ensured by the presence of an O-Ring; therefore it is also possible to clean the internal parts (float and lever) in case of ingress of foreign matter in the valve.

Long-term efficiency and performance of the vent movement is ensured by the valve design features. The seal system is designed to withstand vibrations, therefore it is unaffected by any external vibrations.

If the **DUO, INT, 2161C, MKV, MKL, MHV** or **MHL Series** have to be replaced, the use of the **RIA** or **2311C Series** check valves allows this operation to be performed without the system having to be emptied.

Overall dimensions (mm)

DUO/INT

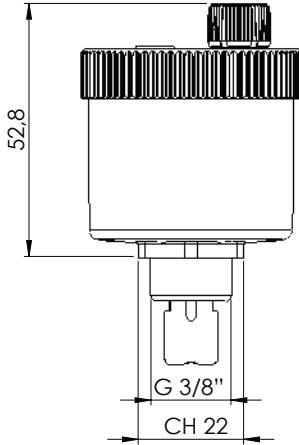

INT/AV15

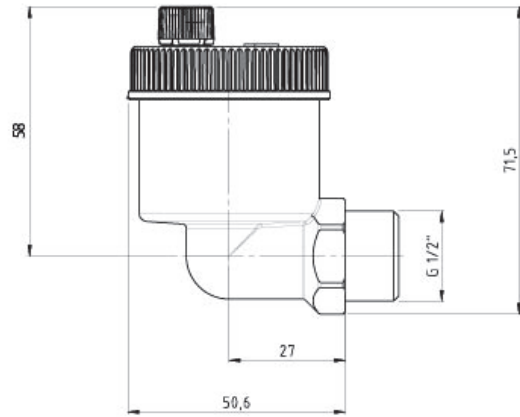

2161C

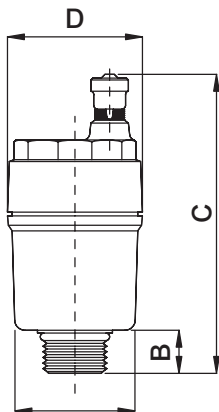

DN	A	B	C	D
3/8"	30	10	77	36
1/2"	30	10	77	36
3/4"	32	12	79	36
1"	37	12	79	36

MKL

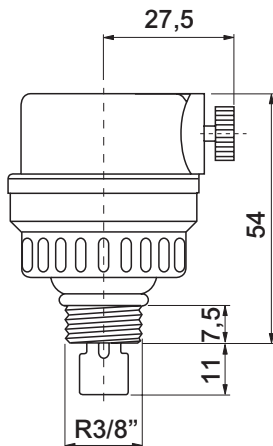

MKV

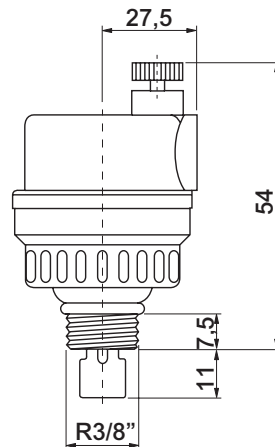

MHL

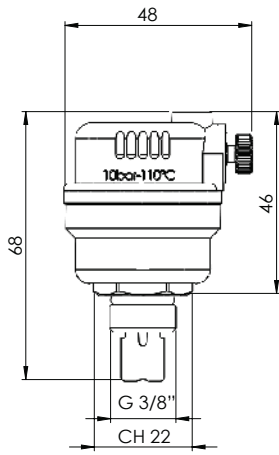

MHV

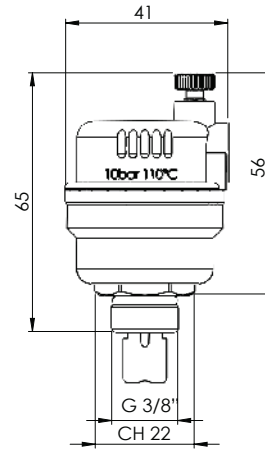

MXV - 3/4" - 1" - 1.1/4"

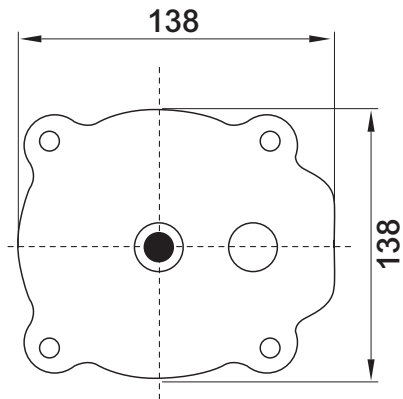
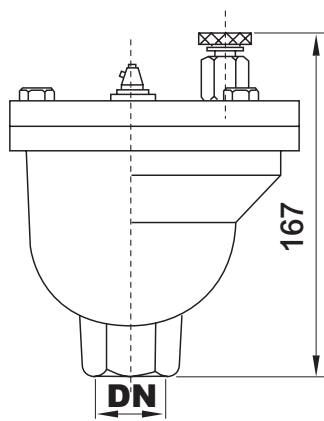

RIA

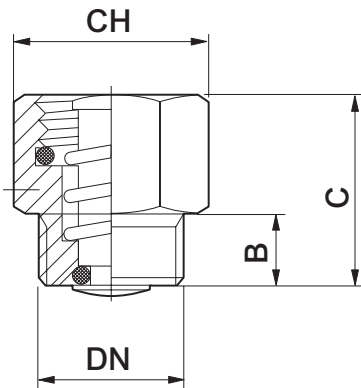

2311C

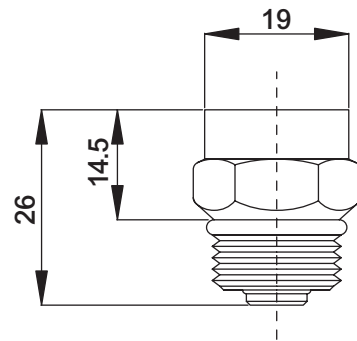

Specification text

DUO Series

Automatic and manual air vent valve **DUO Series** – WATTS brand with removable cover for inspection. Body and cover in brass CW617N. Corrosion-resistant polyethylene float. PN 12. Maximum working pressure: 12 bar. Maximum working temperature: 115°C. Automatic venting capacity at 3 bar: 20 l/min. Manual venting capacity at 3 bar: 100 l/min. Also suitable for water containing additive (glycol up to 50%).

INT Series

Automatic and manual air vent valve **NEW INTERVENT Series** – WATTS brand with removable cover for inspection. Body and cover in brass CW617N. Corrosion-resistant polyethylene float. PN 12. Maximum working pressure: 12 bar. Maximum working temperature: 115°C. Also suitable for water containing additive (glycol up to 50%).

INT/AV15 Series

Automatic and manual air vent valve **NEW INTERVENT Series** – WATTS brand for inspection and lateral connection. Body and cover in brass CW617N. Corrosion-resistant polyethylene float. PN 12. Maximum working pressure: 12 bar. Maximum working temperature: 115°C. Also suitable for water containing additive (glycol up to 50%).

2161C Series

Vertical automatic air vent valve FLOATVENT **2161C Series** – WATTS brand. CW617N brass body. Equipped with O-ring. Suitable for installation on the head connections of coplanar manifolds. PN 10 bar. Max. temperature: 110°C.

MKV Series

Vertical automatic air vent valve MICROVENT **MKV Series** – WATTS brand. CW617N brass body and cover. Equipped with O-ring. PN12. Maximum working pressure: 10 bar Max. temperature: 110°C. Also suitable for water with additive (glycol up to 50%)

MKL Series

Lateral automatic air vent valve MICROVENT **MKL Series** – WATTS brand. CW617N brass body and cover. Equipped with O-ring. PN12. Maximum working pressure: 10 bar Max. temperature: 110°C. Also suitable for water with additive (glycol up to 50%)

MHV Series

Automatic Vertical Air Vent Valve Series HYBRIVENT **MHV Series** – WATTS brand. Brass body CW617N. Composite cover. Pre-sealed connection with O-Ring. PN12. Maximum working pressure: 10 bar. Maximum operating temperature: 110°C. Also suitable for added water (glycols up to 50%)

MHL Series

Automatic Vertical Air Vent Valve Series HYBRIVENT **MHL Series** – WATTS brand. Brass body CW617N. Composite cover. Pre-sealed connection with O-Ring. PN12. Maximum working pressure: 10 bar. Maximum operating temperature: 110°C. Also suitable for added water (glycols up to 50%)

MXV Series

High-flow automatic air vent valve MAXIVENT **MXV Series** – WATTS brand. Equipped with manual vent valve. Cast iron body and cover with epoxy paint finish. PN 12 bar. Max. operating temperature: 100°C. 3/8" F air outlet connection.

The descriptions and photographs contained in this product specification sheet are supplied by way of information only and are not binding.

Watts Industries reserves the right to carry out any technical and design improvements to its products without prior notice. Warranty: All sales and contracts for sale are expressly conditioned on the buyer's assent to Watts terms and conditions found on its website at www.wattswater.eu. Watts hereby objects to any term, different from or additional to Watts terms, contained in any buyer communication in any form, unless agreed to in a writing signed by an officer of Watts.



Watts Industries Italia S.r.l.

Via Brenno, 21 • 20853 Biassono (MB) • Italy

Tel. +39 039 4986.1 • Fax +39 039 4986.222

infowattsitatia@wattswater.com • www.watts.com